

Hose Load
 1:500ft of 2.5"
 2:1200ft of 4"

Left Side Compartmentation				
Compt	Doors	Opening Dimensions	Inside Dimensions	Volume
WxHxD				
L1	Roll Up	54x62	61.25x72x27.25	69.5 CU FT
L2	Roll Up	57x22	64x38x27.25	38.4 CU FT
L3	Roll Up	58x62	65x72x27.25	73.8 CU FT
Right Side Compartmentation				
Compt	Doors	Opening Dimensions	Inside Dimensions	Volume
R1	Roll Up	54x62	61.25x66x27.25	63.7 CU FT
R2	Roll Up	57x22	64x32x27.25	32.3 CU FT
R3	Roll Up	58x62	65x66x27.25	67.7 CU FT
Rear Compartmentation				
Compt	Doors	Opening Dimensions	Inside Dimensions	Volume
A1	Roll Up	35x28	42x38.75x39.25	35.2 CU FT
Coffin Compartmentation				
Compt	Doors	Opening Dimensions	Inside Dimensions	Volume
LxHxW				
LH	Hatch	(3) 55x22	189x26x29	82.5 CU FT
RH	Hatch	(2) 55.5x22	130x32x29	34.9 CU FT

Hale Qmax 1500 single stage
 Water Tank Capacity 1000 gal
 Foam Tank Capacity 50 gal

Total Volume	498.0 CU Ft
--------------	-------------

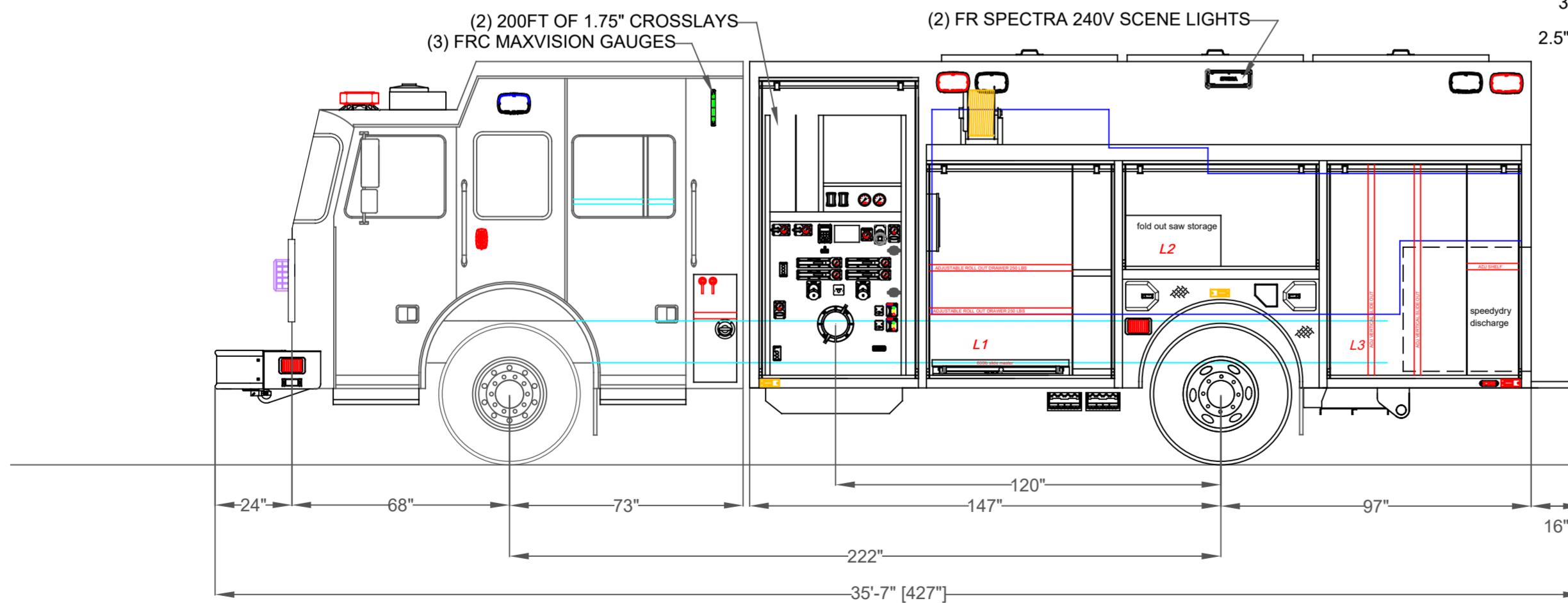

3" LEFT REAR DISCHARGE
 2.5" HOSEBED DISCHARGE

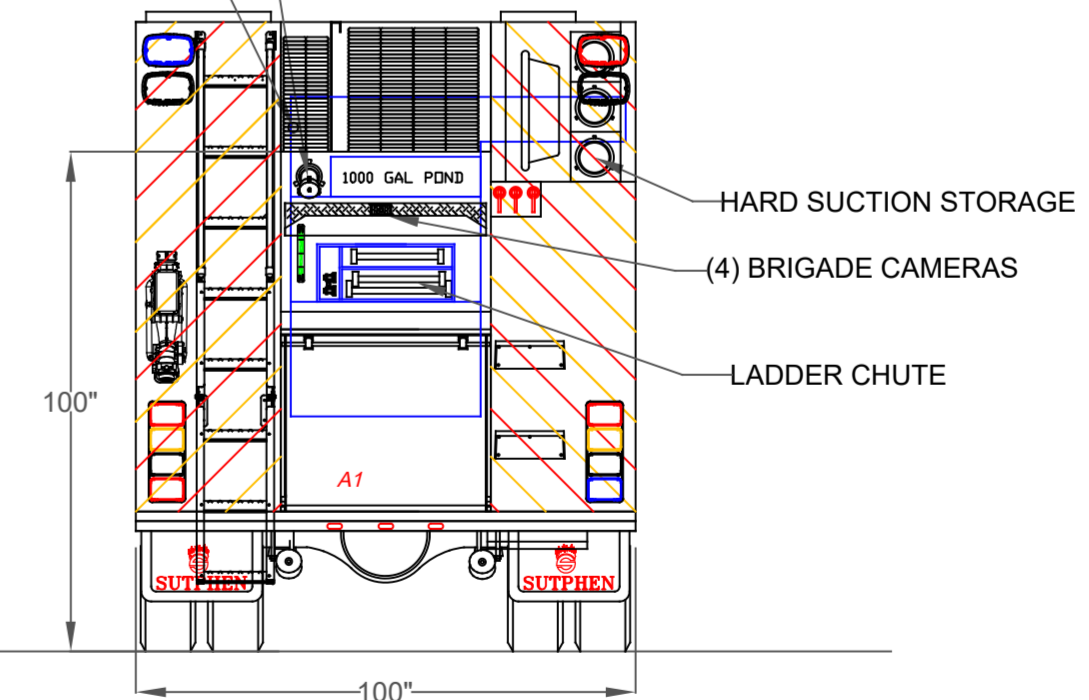

DIMENSIONS SHOWN ON THIS DRAWING ARE APPROXIMATE AND ARE SUBJECT TO MINOR DEVIATIONS DURING CONSTRUCTION.

CUSTOMER APPROVAL

NAME: _____
 TITLE: _____
 DATE: _____

REV.	DESCRIPTION	BY	DATE

THIS PRINT IS PROVIDED ON A RESTRICTED BASIS AND IS NOT TO BE USED IN ANY WAY DETRIMENTAL TO THE INTEREST OF SUTPHEN CORPORATION.

DRAWN BY:
 J. Gordon
 DATE:
 08/10/2018
 MFG. FACILITY:
 SUTPHEN EAST
 LAKE ARIEL, PA



Jefferson Fire Department
 Jefferson, NY

PA-16 Custom Rescue Pumper

DWG. NO.: HS 6317