

Hose Load
 1:300ft of 1.75"
 2:300ft of 2.5"
 3:1000ft of 4"
 4:400ft of 3"
 5: 300ft of 1.75"

FENDER STORAGE
 LFF: TRIPLE SCBA
 LRF: FUEL/SCBA
 RFF: TRIPLE SCBA
 RRF: SINGLE SCBA

LADDER BRACKETS
 24FT 2-SEC
 14FT ROOF
 10FT ATTIC

Left Side Compartmentation				
Compt	Doors	Opening Dimensions	Inside Dimensions	Volume
WxHxD				
L1	Roll Up	38x62	45x72x27.25	51.1 CU FT
L2	Roll Up	57x28	64x38x27.25	38.4 CU FT
L3	Roll Up	48x62	55x72x27.25	65.0 CU FT
Right Side Compartmentation				
Compt	Doors	Opening Dimensions	Inside Dimensions	Volume
R1	Roll Up	38x24	45x34x27.25	24.1 CU FT
R3	Roll Up	48x24	55x34x27.25	29.5 CU FT
Rear Compartmentation				
Compt	Doors	Opening Dimensions	Inside Dimensions	Volume
A1	HINGED	35x10	42x20x29.25	14.2 CU FT
Rear Compartmentation				
Compt	Doors	Opening Dimensions	Inside Dimensions	Volume
LH	HATCH	(2) 68.5x12.5	164x16.5x21	32.9 CU FT
Total Volume				255.2 CU FT

Hale Qmax 1500 single stage
Water Tank Capacity 1000 gal
Foam Tank Capacity 20 gal

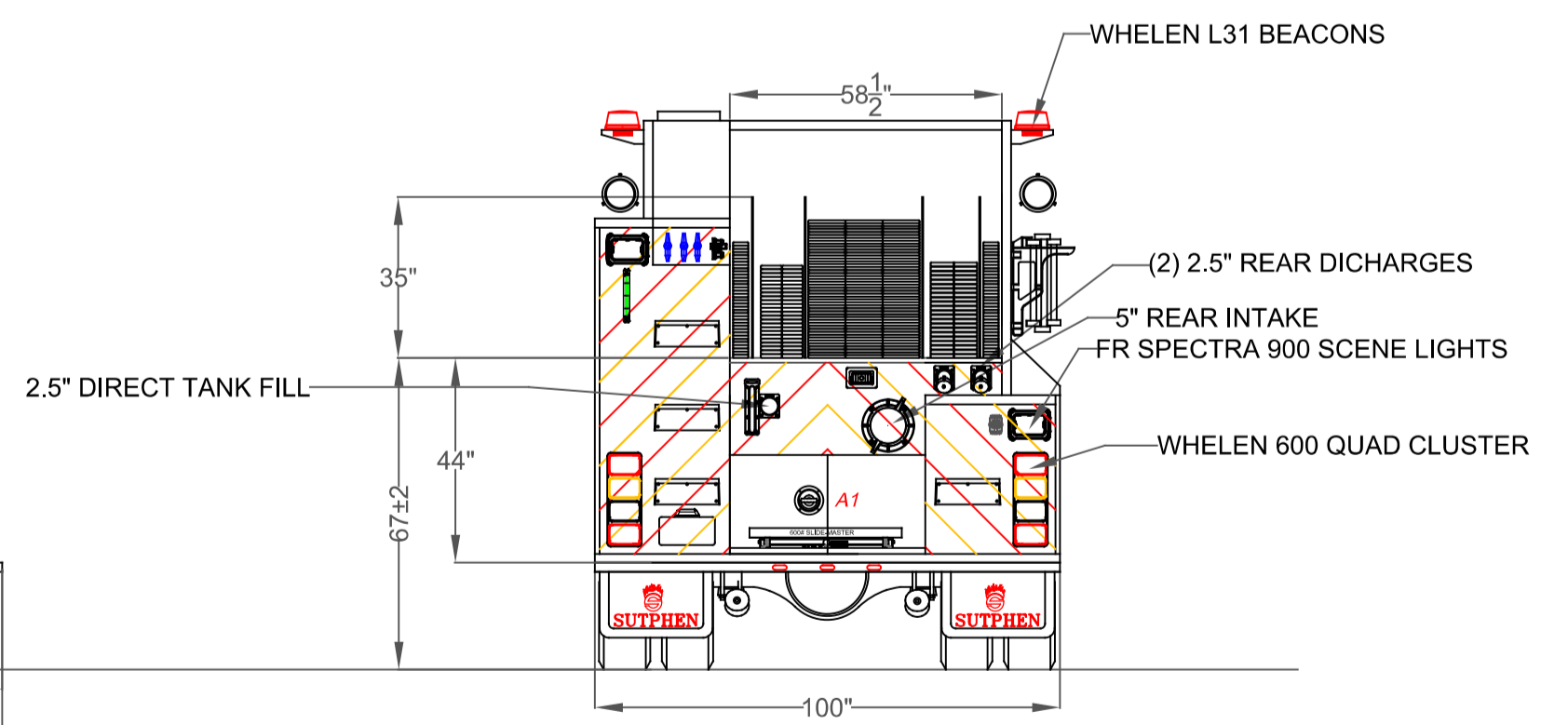
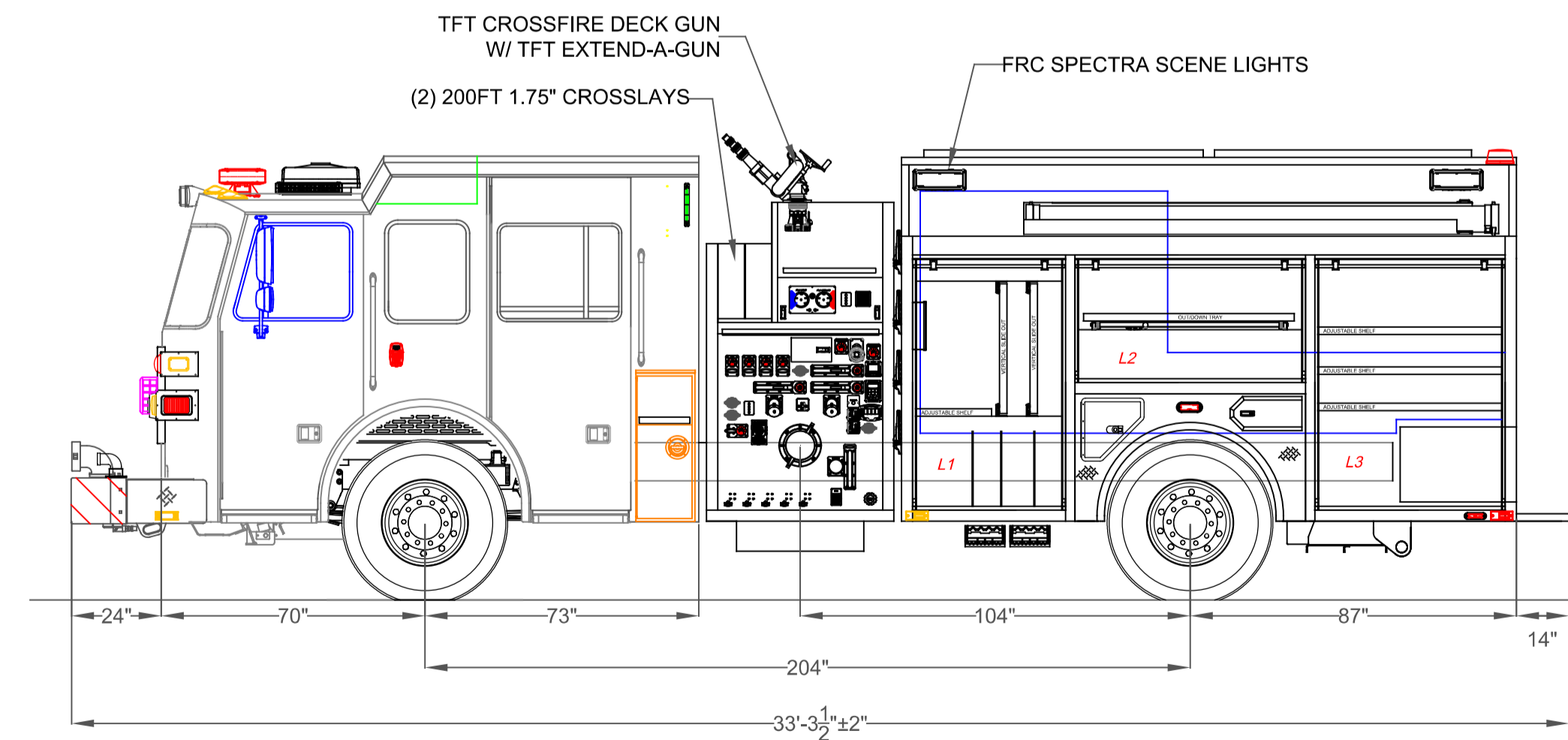

DIMENSIONS SHOWN ON THIS DRAWING ARE APPROXIMATE AND ARE SUBJECT TO MINOR DEVIATIONS DURING CONSTRUCTION.	CUSTOMER APPROVAL		G	ADDED SHELF IN L3 AND R3	JVG	01/10/2025	DRAWN BY: J. GORDON	SUTPHEN EAST 55 INNOVATION DRIVE LAKE ARIEL, PA 1-844-776-2889
	IN THE EVENT OF A DISCREPANCY BETWEEN THE SUTPHEN SPECIFICATIONS AND DRAWING, THE SUTPHEN SPECIFICATIONS SHALL PREVAIL.	NAME:	D	CHANGED HARD SUCTION TO PAINTED ALUMINUM	JVG	10/18/2024		
DRAWING IS FOR REFERENCE ONLY. SOME ITEMS PROPOSED MAY NOT BE SHOWN OR NOTED.		TITLE:	B	CHANGED TO 38" EXT CAB COMPARTMENTS	JVG	08/25/2023	MFG. FACILITY: SUTPHEN EAST LAKE ARIEL, PA	CUSTOM ALUMINUM PUMPER DWG. NO.: HS 7741
	DATE:	A	CHANGES FROM PRE-CON	JVG	01/11/2023			
			REV.	DESCRIPTION	BY	DATE		
THIS PRINT IS PROVIDED ON A RESTRICTED BASIS AND IS NOT TO BE USED IN ANY WAY DETRIMENTAL TO THE INTEREST OF SUTPHEN CORPORATION.								