

COMP'T	INSIDE DIMENSIONS	OPENING SIZE	DOOR TYPE	VOLUME
L1	30"W x 70"H x 24"D	24"W x 62"H	ROLL UP	29.16 CU. FT.
L2	60"W x 40"H x 24"D	54"W x 32"H	ROLL UP	33.33 CU. FT.
L3	47"W x 70"H x 24"D	41"W x 62"H	ROLL UP	45.69 CU. FT.
R1	30"W x 70"H	24"W x 62"H	ROLL UP	
UPPER	35.5"H x 12"D			7.39 CU. FT.
LOWER	34.5"H x 24"D			14.37 CU. FT.
R2	60"W x 40"H x 12"D	54"W x 32"H	ROLL UP	16.66 CU. FT.
R3	47"W x 70"H	41"W x 62"H	ROLL UP	
UPPER	35.5"H x 12"D			11.58 CU. FT.
LOWER	34.5"H x 24"D			22.52 CU. FT.
A1	46"W x 45"H x 24"D	45"W x 35.5"H	ROLL UP	28.75 CU. FT.
P1	23.5"W x 25"H x 74"D		HINGED	25.15 CU. FT.
			TOTAL	234.60 CU. FT.

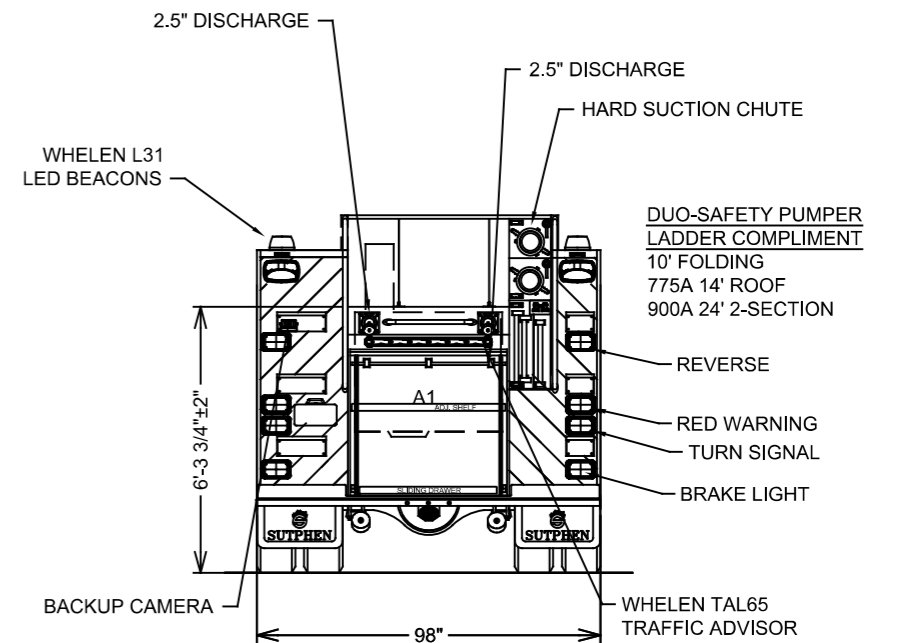
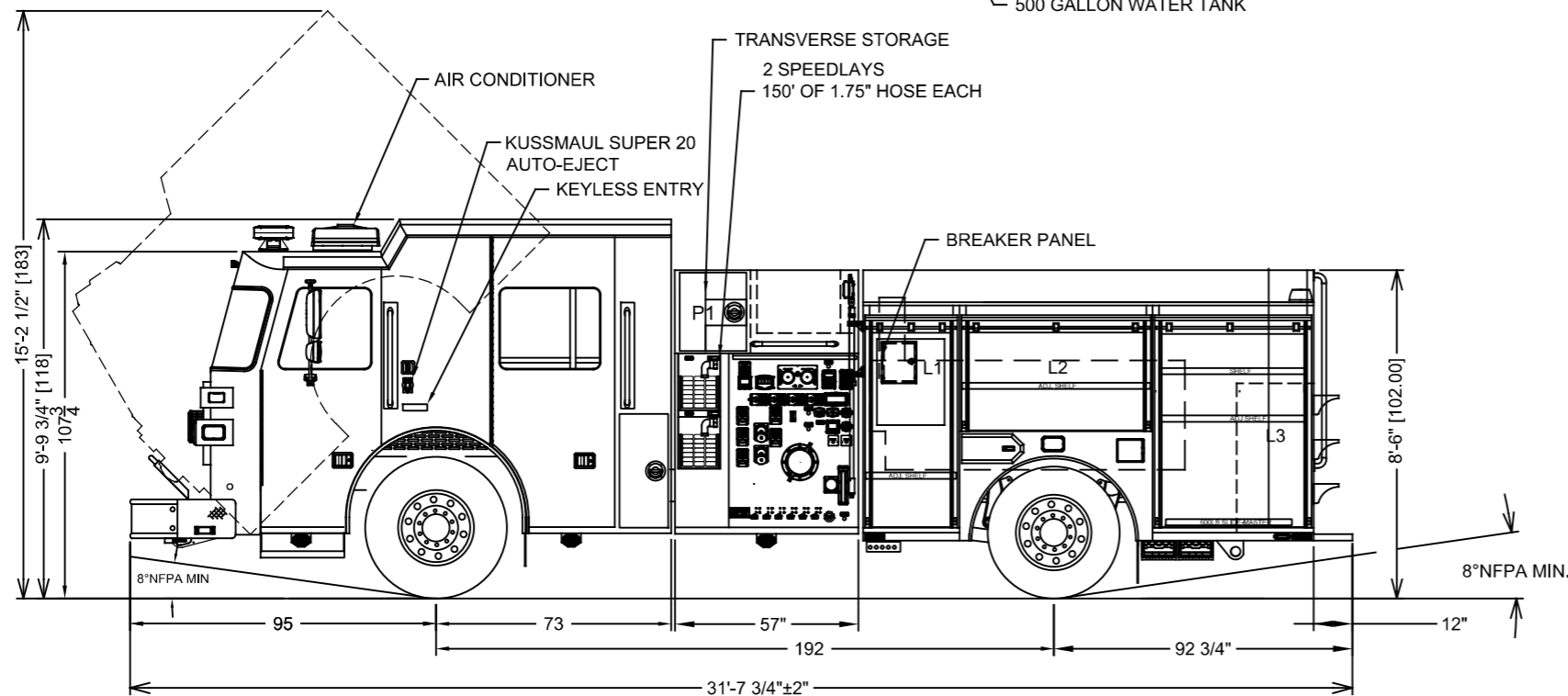

DIMENSIONS SHOWN ON THIS DRAWING ARE APPROXIMATE AND ARE SUBJECT TO MINOR DEVIATIONS DURING CONSTRUCTION.

IN THE EVENT OF A DISCREPANCY BETWEEN THE SUTPHEN SPECIFICATIONS AND DRAWING, THE SUTPHEN SPECIFICATIONS SHALL PREVAIL.

DRAWING IS FOR REFERENCE ONLY. SOME ITEMS PROPOSED MAY NOT BE SHOWN OR NOTED.

CUSTOMER APPROVAL

NAME: _____

TITLE: _____

DATE: _____

REV.	DESCRIPTION	BY	DATE
B	L3_SHELVING_CHANGES	JVG	08/22/2023
A	PRE-CON_CHANGES	JVG	05/25/2023

THIS PRINT IS PROVIDED ON A RESTRICTED BASIS AND IS NOT TO BE USED IN ANY WAY DETRIMENTAL TO THE INTEREST OF SUTPHEN CORPORATION.

DRAWN BY:
J.GORODN

DATE:
06/21/2022

MFG. FACILITY:
EAST

SUTPHEN

CITY OF DAVENPORT
DAVENPORT, IA

CUSTOM STS PUMPER PS-02
HS 7719