



---

**SUTPHEN CORPORATION**  
**MODELS SL75, SA75 & SP70**  
**AERIAL LADDERS & PLATFORM OPERATOR AND**  
**MAINTENANCE MANUAL**



**SUTPHEN**

**IMPORTANT**

**READ AND UNDERSTAND THIS MANUAL BEFORE OPERATING**

**FAILURE TO USE, UNDERSTAND, AND FOLLOW PROPER USAGE INSTRUCTIONS AS MADE AVAILABLE BY SUTPHEN CORPORATION/OPERATOR'S MANUAL, VARIOUS VENDOR SUPPLIED LITERATURE, GUIDELINES OF N.F.P.A., I.S.F.S.I., O.S.H.A., ETC., COULD CAUSE SERIOUS INJURY AND/OR DEATH.**

**SUTPHEN**  
**Since 1890**





---

## Chapter 1 Operator Manual

	<u>Page</u>
1.1 Introduction.....	1-2
1.2 Aerial Operation .....	1-4
<i>Operation Safety Points</i> .....	1-4
1.3 Rates Capacities .....	1-7
1.4 Safety Tags. ....	1-7
<i>Warning/Danger/Caution Labels List</i> .....	1-8
1.5 Cab Setup Procedure .....	1-21
<i>Locating the Vehicle</i> .....	1-21
<i>Activating the Hydraulic System</i> .....	1-21
1.6 Cab Setup for Fire Pump Operation. ....	1-23
1.7 Setup for Simultaneous Tower and Pump Operations.....	1-24
1.8 Aerial Tower Setup Procedures .....	1-24
1.9 Stabilizing System.....	1-27
1.10 Ladder Function Controls .....	1-28
<i>Elevation</i> .....	1-28
<i>Extend/Retract</i> .....	1-29
<i>Rotation</i> .....	1-29
<i>High Speed Controls</i> .....	1-29
<i>Auxiliary Motor Switch</i> .....	1-31
1.11 Safety Interlock System .....	1-32
<i>Interlock Jack Release</i> .....	1-32

▽ **Operator Manual**

1.12	Waterway and Nozzle.....	1-33
1.13	Platform Mounting and Leveling System.....	1-34
	<i>Disabling Electro-Hydraulic Bucket Leveling</i> .....	1-34
	<i>Manual Leveling Override</i> .....	1-35
1.14	Optional Breathing Air Systems.....	1-36
1.15	Platform Anchorage System.....	1-37
1.16	Return Aerial to Travel Position.....	1-38
	<i>Retract the Tower</i> .....	1-38
	<i>Lower the Tower</i> .....	1-38
	<i>Remove Wheel Chocks</i> .....	1-39
	<i>Retract the Stabilizers</i> .....	1-39

**Chapter 2**  
**Maintenance Manual**

		<u>Page</u>
2.1	Aerial Maintenance .....	2-1
	<i>Stabilizers</i> .....	2-1
	<i>Main Lift Cylinders</i> .....	2-1
	<i>Pivot Shaft Bearings</i> .....	2-1
	<i>Turntable Bearing</i> .....	2-1
	<i>Rotation Gear Reducer</i> .....	2-2
	<i>Drive Gears</i> .....	2-3
	<i>Tower Extension/Retraction Cylinder</i> .....	2-3
	<i>Sheaves and Cables</i> .....	2-3
2.2	Extension System.....	2-4
	<i>SL75 Cable Adjustment Procedure</i> .....	2-4
	<i>SA75 Cable Adjustment Procedure</i> .....	2-7
	<i>SP70 Cable Adjustment Procedure</i> .....	2-11
	<i>Slide Blocks</i> .....	2-15
	<i>Waterway and Seals</i> .....	2-15





---

2.3	Water Lubrication Procedure.....	2-16
	<i>Waterway Nozzle</i> .....	2-16
	<i>Platform Mounting and Leveling System</i> .....	2-17
	<i>Hydraulic Oil Tank</i> .....	2-18
	<i>Hydraulic Tank Fill Instruction</i> .....	2-19
2.4	High Pressure Filtration System.....	2-20
2.5	Maintenance of Structure.....	2-20
	<i>Aluminum Tower Structure</i> .....	2-20
	<i>Turntable Attachments</i> .....	2-21
	<i>Attachment of Support Structure to Truck Frame</i> .....	2-21
	<i>Aerial Tower and Ice Build Up</i> .....	2-22
	<i>Aerial Tower Lubrication and Maintenance Schedule</i> .....	2-24
	<i>Torque Specifications</i> .....	2-25
	<i>Walk Around Checks for Mobile Fire Apparatus</i> .....	2-30
	<i>Draining &amp; Winterizing Trucks</i> .....	2-35

### **Chapter 3**

#### **Warranty**

##### Aerial Platform or Aerial Ladder Structural and Corrosion Warranty

    Thirty (30) Years ..... 3-1

##### Aerial Platform and Aerial Ladder Mechanical Warranty

    Two (2) Years ..... 3-2

## **Chapter 1 Operator Manual**

	<u>Page</u>
1.1 Introduction.....	1-2
1.2 Aerial Operation .....	1-4
<i>Operation Safety Points</i> .....	1-4
1.3 Rates Capacities .....	1-7
1.4 Safety Tags. ....	1-7
<i>Warning/Danger/Caution Labels List</i> .....	1-8
1.5 Cab Setup Procedure .....	1-21
<i>Locating the Vehicle</i> .....	1-21
<i>Activating the Hydraulic System</i> .....	1-21
1.6 Cab Setup for Fire Pump Operation. ....	1-23
1.7 Setup for Simultaneous Tower and Pump Operations.....	1-24
1.8 Aerial Tower Setup Procedures .....	1-24
1.9 Stabilizing System.....	1-27
1.10 Ladder Function Controls .....	1-28
<i>Elevation</i> .....	1-28
<i>Extend/Retract</i> .....	1-29
<i>Rotation</i> .....	1-29
<i>High Speed Controls</i> .....	1-29
<i>Auxiliary Motor Switch</i> .....	1-31
1.11 Safety Interlock System .....	1-32
<i>Interlock Jack Release</i> .....	1-32



---

1.12	Waterway and Nozzle.....	1-33
1.13	Platform Mounting and Leveling System.....	1-34
	<i>Disabling Electro-Hydraulic Bucket Leveling</i> .....	1-34
	<i>Manual Leveling Override</i> .....	1-35
1.14	Optional Breathing Air Systems.....	1-36
1.15	Platform Anchorage System.....	1-37
1.16	Return Aerial to Travel Position.....	1-38
	<i>Retract the Tower</i> .....	1-38
	<i>Lower the Tower</i> .....	1-38
	<i>Remove Wheel Chocks</i> .....	1-39
	<i>Retract the Stabilizers</i> .....	1-39

## 1.1 Introduction

This manual has been written by service and engineering specialists. This manual will help acquaint you with the operation and maintenance of your apparatus, as well as the set-up and use of the tower during emergencies. You are urged to read this manual carefully. Following the instructions and recommendations in this manual will help ensure the safe and reliable operation of your apparatus.

After you have read this manual, it should be stored in the apparatus or another location for quick and easy reference for all firefighters.

Throughout this manual, the safety signal words **WARNING**, **DANGER**, and **CAUTION** appear. These serve as a reminder to follow all instructions carefully. Failure to follow instructions can cause personal injury or damage to your apparatus.

There may be circumstances that arise throughout the life of this apparatus which do not appear in this manual. At all times, common sense and safety should be your first consideration.

Thank you for purchasing your apparatus from Sutphen. We work toward giving you complete satisfaction. Sutphen knows your apparatus best and has the parts and factory-trained technicians available. Please do not hesitate to contact Sutphen at 1-866-287-5549.



Auxiliary ground pads should always be used under the outrigger feet when operating the aerial tower.

Do not use auxiliary ground pads under the rear jacks unless they are metal, as these jacks are used as a grounding point.

Safety lock pins on stabilizers shall always be in place.

Never move the vehicle with stabilizers in contact with ground.

Most problems encountered with operation of the tower are caused by inadequate maintenance. To keep the tower fully operational, routine lubrication policies must be followed.

The aerial should be inspected and tested annually in accordance with NFPA 1910, Testing Fire Department Aerial Apparatus.

Frequently inspect the chassis and running gear and maintain in good mechanical condition following recommended schedules in this manual. The aerial tower is of no use unless it can be transported to where it is needed. Careful, safe driving rules should be observed for the same reason.

Carefully and frequently check and inspect the entire aerial for loose bolts or rivets, un-lubricated bearing surfaces, bent, warped, or twisted parts, hydraulic leaks, defective electric control equipment, etc. Follow the recommended maintenance schedules in this manual.

All members should frequently practice the different phases of aerial operations.

Never set up the aerial on marshy ground, freshly filled ground, or other soft surface.

▽ **Operator Manual**

## **1.2 Aerial Operation**

### **Operation Safety Points**

The aerial tower is only as good or as safe as the operator is competent. Continued training and familiarization is essential.

An operator **MUST** be at the lower control station anytime the aerial is being operated.

Do not operate turntable controls while personnel are climbing the tower.

Personnel should use an approved life belt when operating on the aerial tower. At night, the entire aerial tower should be well lighted.

Do not forcefully extend the end of the tower against a structure.

Never use the aerial as a battering ram.

Never use the aerial for pulling down walls or structural members.

Never willingly or intentionally abuse an aerial by careless handling, overloading, or use for which it was not designed.

Operate the aerial with deliberate motions and smooth application of power. Stabilizers with ground pads should always be used when operating the aerial ladder.

Safety locks on stabilizers should always be in place.

Training and practice with the apparatus on a regular basis is a must for safe operation.



---

Never apply opposing alternating control when operating the aerial, either in a side-to-side motion, a front-to-rear motion, or an up-and-down motion. This may set up an accelerated oscillation, which could put undue strain on the structure and cause immediate or eventual failure of the aerial tower and injury to the occupants and bystanders.

Do not overload the aerial. Learn and observe the load limit indicated at the operator's positions.

When raising an aerial platform to rescue people at roofs or windows, avoid raising the platform in line with the people. Either raise off to one side and rotate to the people or raise perpendicular to them and rotate toward them. This is because panic-stricken persons seeing the platform within reach below them could try jumping into it.

Although the aerial is designed for one person setup, it is a good safety practice to designate a person to observe the right-side stabilizer when the stabilizers are being set up. This person can place the stabilizer pad and observe that it is placed evenly and correctly and that the stabilizer is set properly.

Many accidents with aerial devices nationwide occur during nonemergency operation. For this reason, the aerial should not be operated by one person alone. Operators checking out or operating the tower alone in front of the station can forget something or be overconfident and get into trouble. “Two heads are better than one”.

Never allow an untrained person or a person who is not thoroughly familiar with this aerial to operate it unless constantly supervised.

**Operator Manual**

The operator must:

1. Be capable of spotting the vehicle properly.
2. Be able to stabilize the vehicle properly.
3. Know the location of every control.
4. Know what each control does and how it works.
5. Be able to operate all controls smoothly and safely.
6. Know the location of safety devices, how they work and how to operate.
7. Be familiar with the loads that the tower can safely accommodate under various operating conditions.
8. Be aware of how to operate the tower under unusual circumstances.

When you consider the lives at stake, the cost of an aerial tower and the damage that could occur to the equipment, the importance of training and practice becomes very clear.



**WARNING**

*Before operating this apparatus, you must:*

- 1. Be thoroughly familiar with this instruction manual.*
- 2. Be thoroughly trained in the operation of this apparatus.*
- 3. Operate this apparatus in strict accordance with the manufacturer's recommendations.*
- 4. Operate this apparatus in accordance with departmental rules and regulations.*
- 5. Always set up the apparatus on concrete, blacktop, or gravel. Surface must be firm and solid.*

*Failure to do so could result in injury or death to persons operating or working on or around this apparatus.*

*Failure to do so could also result in damage to this apparatus.*





---

## 1.3 Rated Capacities

### **65' & 75' Aerials (Built Prior to August 18, 2006)**

The rated capacity of the 65' and 75' aerials is 500 lbs. with or without water in the waterway, in an position of operation.

### **70' Platforms (SP70) (Built Prior to August 18, 2006)**

The rated capacity of the 70' aerial platform is 500 lbs. with water in the waterway, 750 lbs. without water in the waterway, in any position of operation.

### **75' Aerials (SA75) and 70' Platforms (SP70) (Built After August 18, 2006)**

The rated capacity of the 70' aerial platform and the 75' box boom is 750 lbs. with water in the waterway, 1000 lbs. without water in the waterway, in any position.

### **75' Aerials (SL75)**

The rated capacity of the 75' aerial ladder is 750 lbs. with water in the waterway, 1000 lbs. without water in the waterway, in any position of operation.



## **WARNING**

*DO NOT exceed the rated capacities.*

## 1.4 Safety Tags

On the following pages are the various safety tags found on the apparatus. All of the tags found here may not be used on your particular vehicle, as some are related to optional equipment. Should any of these tags become damaged or lost throughout the life of your vehicle, please contact Sutphen Corporation at 1-866-287-5549 for replacements.

**Operator Manual**

## WARNING / DANGER / CAUTION LABELS LIST

Tag 010	Alignment Light	Tag 370	Platform Equipment
Tag 015	Aerial Modification Warning	Tag 371	Drain Yoke Caution
Tag 016	Oil Caution	Tag 375	Set Rear Jacks Caution
Tag 017	Avoid Electrocutation Danger	Tag 381	ABS Code Switch
Tag 018	Pinch Point Caution	Tag 382	Pressurized Inlets Warning
Tag 019	Stand Clear Crushing Injury Warning	Tag 385	Jump Stud
Tag 020	Aerial Electrocutation Danger	Tag 395C	Pump Overheat Procedure
Tag 022	Climb Boom Danger	Tag 405	Power Line Down
Tag 023	Aerial Data	Tag 406	Manual Override Outrigger Controls
Tag 036	Fire Caution	Tag 407B	Turntable Area Instruction
Tag 037	Enclosed Seats Warning	Tag 408B	Down to Lock
Tag 038	Fumes Caution	Tag 410	Do Not Walk Warning
Tag 038-1	Horizontal Fumes Caution	Tag 416	Safety Chain Fastened Warning
Tag 055	Battery Safety Precaution	Tag 417	Engage Generator Instruction
Tag 056	Explosion Warning	Tag 427B	Bumper Warning
Tag 057A	Seated & Belted Warning	Tag 428	Pump Valve Handle Warning
Tag 058	Traction Warning	Tag 430	Sutphen Towers Pump Data
Tag 059	Fan Warning	Tag 431	Chassis Data
Tag 060	Close Crosslay Cover Warning	Tag 432	Fluid Data
Tag 066	Stand Clear of Outrigger Warning	Tag 433	Power Source Specs.
Tag 21B	Lifting Eye Warning	Tag 434B	Front Suction Elbow Caution
Tag 281	Tire Chains Instruction	Tag 437	Ladder Rack Up/Down
Tag 282	Stabilizer Interlock System	Tag 438	Waterway Valve Override
Tag 310	Computer Code Switch	Tag 440	Equipment Weight Limit
Tag 322	Lowering Cab Warning	Tag 442B	Lifting Eye Warning
Tag 323A	Cab Safety Precautions	Tag 446	Lifting Eye Capacity
Tag 324	Cab Tilt	Tag 448	Differential Lock Engagement
Tag 325	Cab Tilt Latch	Tag 449B	Water Tank Refill Caution
Tag 326	Aerial Rappel Warning	Tag 450B	Pressure Governor RPM Warning
Tag 327	Leveling Override Instruction	Tag 452	Generator PTO
Tag 328	Open Valves	Tag 454B	Generator Wattage Caution
Tag 365	Vehicle Capacity & Height Warning	Tag 455	Ladder Belt Tie-Off Point Warning
Tag 368	Engage PTO Instruction	Tag 499	Sutphen Logo



Sutphen Tag 10  
IC Assembly P/N 3000573-0003  
IC Label P/N 3000575-0003  
IC Bezel P/N 3000574  
Assembly, Size B Message Bezel with Alignment Light Label

TAG 010



Sutphen Tag 15-A  
IC Assembly P/N 3000587-0017  
IC Label P/N 3000588-0017  
IC Bezel P/N 3000586  
Assembly, Size D Message Bezel with Aerial Modification Warning Label

TAG 015



Sutphen Tag 16  
IC Assembly P/N 3000587-0022  
IC Label P/N 3000588-0022  
IC Bezel P/N 3000586  
Assembly, Size D Message Bezel with Oil Caution Label

TAG 016



Sutphen Tag 17  
IC Assembly P/N 3000587-0025  
IC Label P/N 3000588-0025  
IC Bezel P/N 3000586  
Assembly, Size D Message Bezel with Avoid Electrocution Danger Label

TAG 017



Sutphen Tag 18-A  
IC Assembly P/N 3000587-0021  
IC Label P/N 3000588-0021  
IC Bezel P/N 3000586  
Assembly, Size D Message Bezel with Pinch Point Caution Label

TAG 018



Sutphen Tag 19-A  
IC Assembly P/N 3000587-0002  
IC Label P/N 3000588-0002  
IC Bezel P/N 3000586  
Assembly, Size D Message Bezel with Stand Clear Crushing Injury Warning Label

TAG 019

Operator Manual



Sutphen Tag 20  
IC Assembly P/N 3000587-0026  
IC Label P/N 3000588-0026  
IC Bezel P/N 3000586  
Assembly, Size D Message Bezel with  
Aerial Electrocution Danger Label

TAG 020



Sutphen Tag 21-B  
IC Label P/N 3001032-0001  
Lifting Eye Warning Label

TAG 021B



Sutphen Tag 22  
IC Assembly P/N 3000587-0027  
IC Label P/N 3000588-0027  
IC Bezel P/N 3000586  
Assembly, Size D Message Bezel with  
Climb Boom Danger Label

TAG 022

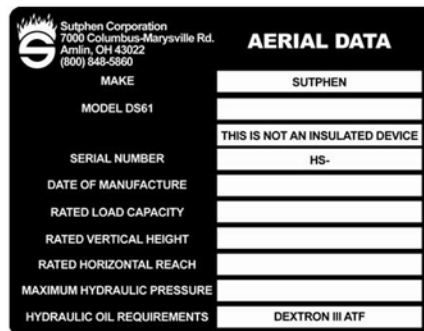

Sutphen Tag 23  
IC Label P/N 3001025-0001  
Aerial Data Label

TAG 023



Sutphen Tag 36-A  
IC Assembly P/N 3000587-0018  
IC Label P/N 3000588-0018  
IC Bezel P/N 3000586  
Assembly, Size D Message Bezel with  
Fire Caution Label

TAG 036



Sutphen Tag 37-A  
IC Assembly P/N 3000587-0010  
IC Label P/N 3000588-0010  
IC Bezel P/N 3000586  
Assembly, Size D Message Bezel with  
Enclosed Seats Warning Label

TAG 037



Sutphen Tag 38  
IC Assembly P/N 3000587-0019  
IC Label P/N 3000588-0019  
IC Bezel P/N 3000586  
Assembly, Size D Message Bezel with  
Fumes Caution Label

TAG 038

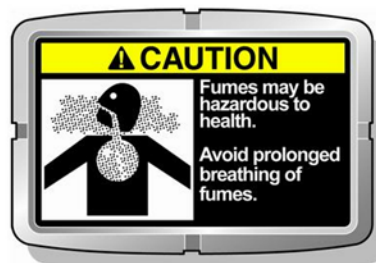

Sutphen Tag 38-1-A  
IC Assembly P/N 3000587-0106  
IC Label P/N 3000588-0106  
IC Bezel P/N 3000586  
Assembly, Size D Message Bezel with  
Horizontal Fumes Caution Label

TAG 038-1

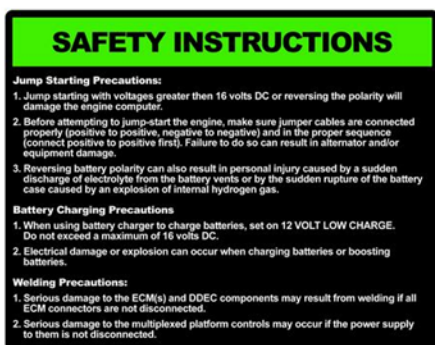

Sutphen Tag 55-A  
IC Label P/N 3001029-0001  
Battery Safety Precautions Label

TAG 055



Sutphen Tag 56-A  
IC Assembly P/N 3000587-0008  
IC Label P/N 3000588-0008  
IC Bezel P/N 3000586  
Assembly, Size D Message Bezel with  
Explosion Warning Label

TAG 056



Sutphen Tag 57-A  
IC Assembly P/N 3000587-0001  
IC Label P/N 3000588-0001  
IC Bezel P/N 3000586  
Assembly, Size D Message Bezel with  
Seated and Belted Warning Label

TAG 057A



Sutphen Tag 58  
IC Assembly P/N 3000587-0012  
IC Label P/N 3000588-0012  
IC Bezel P/N 3000586  
Assembly, Size D Message Bezel with  
Traction Warning Label

TAG 058

▽ **Operator Manual**



Sutphen Tag 59-A  
IC Assembly P/N 3000587-0006  
IC Label P/N 3000588-0006  
IC Bezel P/N 3000586  
Assembly, Size D Message Bezel with Fan Warning Label

**TAG 059**



Sutphen Tag 60-A  
IC Assembly P/N 3000587-0007  
IC Label P/N 3000588-0007  
IC Bezel P/N 3000586  
Assembly, Size D Message Bezel with Close Crosslay Cover Warning Label

**TAG 060**



Sutphen Tag 66-A  
IC Assembly P/N 3000587-0003  
IC Label P/N 3000588-0003  
IC Bezel P/N 3000586  
Assembly, Size D Message Bezel with Stand Clear of Outrigger Warning Label

**TAG 066**

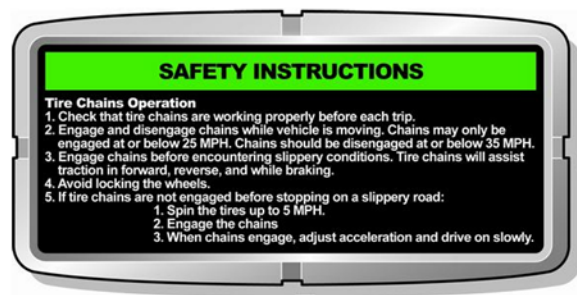

Sutphen Tag No. 281  
IC Assembly P/N 3000573-0002  
IC Label P/N 3000575-0002  
IC Bezel P/N 3000574  
Assembly, Size B Message Bezel with Tire Chains Instruction Label

**TAG 281**



Sutphen Tag 282  
IC Label P/N 3001037-0001  
Stabilizer Interlock System Label

**TAG 282**

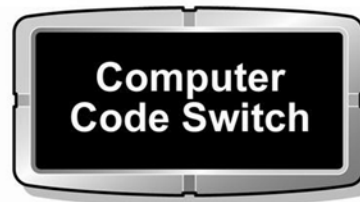

Sutphen Tag 310  
IC Assembly P/N 3000582-0003  
IC Label P/N 3000584-0003  
IC Bezel P/N 3000583  
Assembly, Size C Message Bezel with Computer Code Switch Label

**TAG 310**





Sutphen Tag 322-A  
IC Assembly P/N 3000587-0004  
IC Label P/N 3000588-0004  
IC Bezel P/N 3000586  
Assembly, Size D Message Bezel with Lowering Cab Warning Label

TAG 322

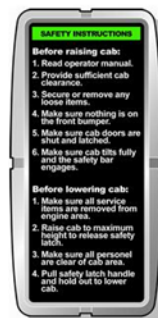

Sutphen Tag 323A  
IC Assembly P/N 3000573-0001  
IC Label P/N 3000575-0001  
IC Bezel P/N 3000574  
Assembly, Size B Message Bezel with Cab Safety Precautions Label

TAG 323A



Sutphen Tag 324  
IC Assembly P/N 3000582-0001  
IC Label P/N 3000584-0001  
IC Bezel P/N 3000583  
Assembly, Size C Message Bezel with Cab Tilt Label

TAG 324



Sutphen Tag 325-A  
IC Assembly P/N 3000582-0004  
IC Label P/N 3000584-0004  
IC Bezel P/N 3000583  
Assembly, Size C Message Bezel with Cab Tilt Latch Label

TAG 325



Sutphen Tag 326-A  
IC Label P/N 3001033-0001  
Aerial Rappel Warning Label  
50% Scale

TAG 326

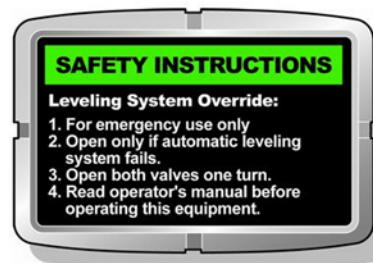

Sutphen Tag 327  
IC Assembly P/N 3000587-0031  
IC Label P/N 3000588-0031  
IC Bezel P/N 3000586  
Assembly, Size D Message Bezel with Leveling Override Instruction Label

TAG 327

Operator Manual



Sutphen Tag 328  
IC Assembly P/N 3000587-0028  
IC Label P/N 3000588-0028  
IC Bezel P/N 3000586  
Assembly, Size D Message Bezel with  
Open Valves Fall Hazard Danger Label

TAG 328



Sutphen Tag 365  
IC Assembly P/N 3000587-0016  
IC Label P/N 3000588-0016  
IC Bezel P/N 3000586  
Assembly, Size D Message Bezel with  
Vehicle Capacity and Height Warning Label

TAG 365

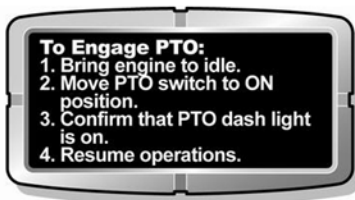

Sutphen Tag 368  
IC Assembly P/N 3000582-0005  
IC Label P/N 3000584-0005  
IC Bezel P/N 3000583  
Assembly, Size C Message Bezel with  
Engage PTO Instruction Label

TAG 368



Sutphen Tag 370  
IC Label P/N 3001036-0001  
Platform Equipment Label

TAG 370



Sutphen Tag 371  
IC Assembly P/N 3000587-0049  
IC Label P/N 3000588-0049  
IC Bezel P/N 3000586  
Assembly, Size D Message Bezel with  
Drain Yoke Caution Label

TAG 371



Sutphen Tag 375  
IC Assembly P/N 3000587-0024  
IC Label P/N 3000588-0024  
IC Bezel P/N 3000586  
Assembly, Size D Message Bezel with  
Set Rear Jacks Caution Label

TAG 375



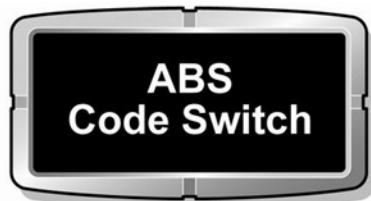

**Sutphen Tag 381 -A**  
**IC Assembly P/N 3000582-0002**  
**IC Label P/N 3000584-0002**  
**IC Bezel P/N 3000583**  
**Assembly, Size C Message Bezel with**  
**ABS Code Switch Label**

**TAG 381**



**Sutphen Tag 382**  
**IC Assembly P/N 3000587-0009**  
**IC Label P/N 3000588-0009**  
**IC Bezel P/N 3000586**  
**Assembly, Size D Message Bezel with**  
**Pressurized Inlets Warning Label**

**TAG 382**



**Sutphen Tag 385**  
**IC Label P/N 3001294-0001**  
**Jump Stud Label**  
**50% Scale**

**TAG 385**



**Sutphen Tag 395-C**  
**IC Assembly P/N 3000587-0020**  
**IC Label P/N 3000588-0020**  
**IC Bezel P/N 3000586**  
**Assembly, Size D Message Bezel with**  
**Pump Overheat Procedure Label**

**TAG 395C**



**Sutphen Tag 405-A**  
**IC Label P/N 3001033-0002**  
**Power Line Danger Label**  
**50% Scale**

**TAG 405**

UP	RET	RET	RET	RET	UP	UP	UP
Front Axle Lock	Left Front Stabilizer	Left Rear Stabilizer	Right Front Stabilizer	Right Rear Stabilizer	Right Stabilizer	Left Stabilizer	Rear Stabilizer
DOWN	EXT	EXT	EXT	EXT	DOWN	DOWN	DOWN

**Sutphen Tag 406-A**  
**IC Label P/N 3001035-0001**  
**Manual Override Outrigger Controls Label**  
**50% Scale**

**TAG 406**

▽ **Operator Manual**



Sutphen Tag 407-B  
IC Assembly P/N 3000587-0011  
IC Label P/N 3000588-0011  
IC Bezel P/N 3000586  
Assembly, Size D Message Bezel with  
Turntable Area Instruction Label

TAG 407B



Sutphen Tag 408-B  
IC Label P/N 3001034-0001  
Down to Lock Label

TAG 408B



Sutphen Tag 410-A  
IC Assembly P/N 3000587-0013  
IC Label P/N 3000588-0013  
IC Bezel P/N 3000586  
Assembly, Size D Message Bezel with  
Do Not Walk Warning Label

TAG 410



Sutphen Tag No. 410-B  
IC P/N 3001030-0001  
Exiting Cab Caution Label

TAG 410B



Sutphen Tag 416-B  
IC Assembly P/N 3000587-0005  
IC Label P/N 3000588-0005  
IC Bezel P/N 3000586  
Assembly, Size D Message Bezel with  
Safety Chain Fastened Warning Label

TAG 416

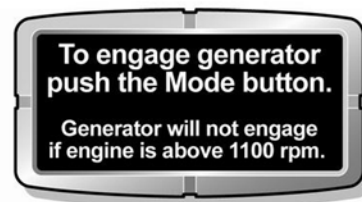

Sutphen Tag 417-A  
IC Assembly P/N 3000582-0006  
IC Label P/N 3000584-0006  
IC Bezel P/N 3000583  
Assembly, Size C Message Bezel with  
Engage Generator Instruction Label

TAG 417



**Sutphen Tag 427-B**  
**IC Assembly P/N 3000587-0034**  
**IC Label P/N 3000588-0034**  
**IC Bezel P/N 3000586**  
**Assembly, Size D Message Bezel with Bumper Warning Label**

## TAG 427B

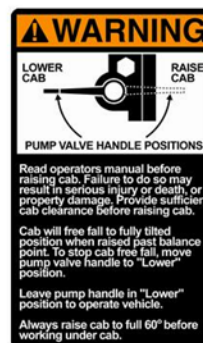

**Sutphen Tag 428**  
**IC Label P/N 3001031-0001**  
**Pump Valve Handle Warning Label**

## TAG 428

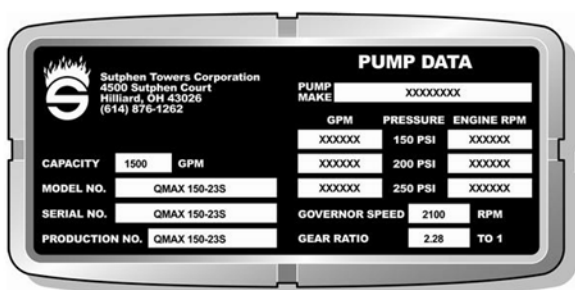

**IC Assembly P/N 3000576-0001-SUTT**  
**IC Label P/N 3000578-0001-SUTT**  
**IC Bezel P/N 3000577**  
**Assembly, Size A Message Bezel with Sutphen Towers Pump Data Label**

## TAG 430



**Sutphen Tag 431**  
**IC Label P/N 3001026-0001**  
**Chassis Data Label**

## TAG 431

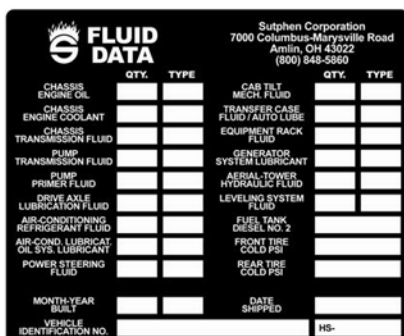

**Sutphen Tag 432**  
**IC Label P/N 3001027-0001**  
**Fluid Data Label**

## TAG 432

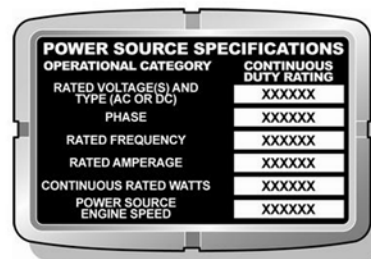

**Sutphen Tag 433**  
**IC Assembly P/N 3000587-0044**  
**IC Label P/N 3000588-0044**  
**IC Bezel P/N 3000586**  
**Assembly, Size D Message Bezel with Power Source Specs. Label**

## TAG 433

▼ **Operator Manual**



Sutphen Tag 434-B  
IC Label P/N 3001658  
Keep Legs Inside Kick Guard Warning Label

TAG 434B



Sutphen Tag 435 A  
IC Assembly P/N 3000582-0017  
IC Label P/N 3000584-0017  
IC Bezel P/N 3000583  
Assembly, Size C Message Bezel with  
Auto-Pump Compressor Drain Label

TAG 435



Sutphen Tag 436-B  
IC Assembly P/N 3000587-0102  
IC Label P/N 3000588-0102  
IC Bezel P/N 3000586  
Assembly, Size D Message Bezel with  
Front Suction Elbow Caution Label

TAG 436B



Sutphen Tag 437  
IC Assembly P/N 3000582-0018  
IC Label P/N 3000584-0018  
IC Bezel P/N 3000583  
Assembly, Size C Message Bezel with  
Ladder Rack Up/Down Label

TAG 437



Sutphen Tag 438  
IC Assembly P/N 3000587-0103  
IC Label P/N 3000588-0104  
IC Bezel P/N 3000586  
Assembly, Size D Message Bezel with  
Waterway Valve Override Label

TAG 438



Sutphen Tag 440  
IC Assembly P/N 3000587-0104  
IC Label P/N 3000588-0104  
IC Bezel P/N 3000586  
Assembly, Size D Message Bezel with  
Equipment Weight Limit Label

TAG 440



UP Front Axle Lock	RET Right Front Stabilizer	RET Left Front Stabilizer	UP Right Stabilizer	UP Left Stabilizer	UP Rear Stabilizer
DOWN	EXT	EXT	DOWN	DOWN	DOWN

Sutphen Tag No. 441  
 IC Label P/N 3001397-0001  
 Manual Override Outrigger Controls Label (SPH)  
 50% Scale



Sutphen Tag 442-B  
 IC Label P/N 3001932-0002  
 Lifting Eye Warning Label

## TAG 441

## TAG 442B



Sutphen Tag 446  
 IC Label P/N 3001434-0001  
 Lifting Eye Capacity Label

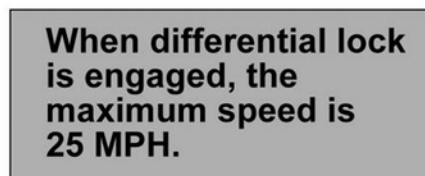

Sutphen Tag 448  
 IC Label P/N 300584-0018  
 Differential Lock Engagement Label

## TAG 446

## TAG 448



Sutphen Tag 449-B  
 IC Assembly P/N 3000582-0021  
 IC Label P/N 3000584-0021  
 IC Bezel P/N 3000583  
 Assembly, Size C Message Bezel with  
 Water Tank Refill Caution Label

## TAG 449B



Sutphen Tag 450-B  
 IC Assembly P/N 3000587-0110  
 IC Label P/N 3000588-0110  
 IC Bezel P/N 3000586  
 Assembly, Size D Message Bezel with  
 Pressure Governor RPM Warning Label

## TAG 450B



▽ **Operator Manual**



**Sutphen Tag 452-A**  
**IC P/N 3001514-0001**  
**Generator PTO Label**

TAG 452



Sutphen Tag 454-B  
IC Assembly P/N 3001499-0016  
IC Label P/N 3001497-0016  
IC Bezel P/N 3001469  
Assembly, Size E Message Bezel with  
Generator Wattage Caution Label

TAG 454B



**Sutphen Tag No. 455-A**  
**IC Label P/N 3001525-0001**  
**Ladder Belt Tie-Off Point Warning Label**

TAG 455



Sutphen Tag CHT-499  
IC Label P/N 3001431-0001  
Sutphen Logo Label

TAG 499



## 1.5 Cab Setup Procedures

### Locating the Vehicle

1. Make sure apparatus is on firm pavement, and that it is clear of overhead obstacles, such as poles, trees, wires, building overhang, etc.
2. Make sure that the stabilizers are not going to sit upon manhole covers, drains, or grates in the street or on sidewalks.
3. Good judgment must be used in locating the apparatus at the fire scene. Ideal conditions may not always exist, so caution must be used to determine as safe a location as possible for the apparatus.
4. Spot the rig about 20 feet from the building when possible. This will give you maximum vertical coverage of the building.
5. Set the parking brake.
6. Place the transmission in neutral.

### Activating the Hydraulic System

There is a PTO (Power Take-Off) which operates the hydraulic pump, providing hydraulic pressure to the system.



### CAUTION

*An electric switch located near the center of the cab dash panel activates the PTO. A pilot light will come on when the PTO switch is moved to the “on” position.*

1. Engine must be at idle RPM.
2. Be sure there is at least 90 lbs. of air pressure on the truck air system.
3. The truck must be at complete stop, parking brake set, and transmission in neutral (N).
4. Move PTO switch on dash to “on” position. (Wait about 2 seconds.)

The cab controls are now set to operate the hydraulic system.

▽ **Operator Manual**



If the fire pump is **not** to be used, proceed to **AERIAL SET-UP** on page 1-23 of this manual. The operator should move to the hydraulic system control compartment, located at the driver side.



**Mode Button and Pilot Light (1) for Generator PTO**





## 1.6 Cab Setup for Fire Pump Operation

**NOTE: See Fire Pump Manual for more detailed information.**

1. The truck must be stopped and parking brake set.
2. Truck transmission must be in neutral (N) position.
3. Engine must be at idle RPM.
4. Move the pump shift lever from ROAD position to PUMP position. Do this by pulling back on the lever. At the same time the pump shift is activated, the lock-up for the automatic transmission is also engaged. The pump shift lever holds the transmission in the pumping gear position.



**Air Pump Shift**



**Electronic Pump Shift**

5. Shift transmission to drive (D) (1-4) position. Power from the engine is now being transferred to the pump drive gear. Observe the illuminated green indicator light next to the shift lever. If the light is not on, the pump is not engaged, pause for 3 seconds, then repeat steps 1-5 and observe for pump engagement.
6. To have the pump ready for operation later, leave transmission selector in neutral (N). For pump operation, simply put transmission selector in drive (D) (1-4).

**Operator Manual**

**NOTE:** Upon arrival at a structure fire or other incident where the tower is not immediately needed, but the fire pump is being used, it is a good practice to place the PTO in gear before placing the fire pump in gear. Should a need to use the tower arise, and the fire pump is being used, the stabilizers can be set, and the tower is then ready for immediate use. If the PTO was not engaged before the pump was set up, it would be necessary to slow the engine to an idle to engage the PTO, jeopardizing fire fighting operations.

## 1.7 Setup for Simultaneous Aerial and Pump Operations

1. Follow steps for placing PTO in gear on page 1-20.
2. Follow Aerial ladder setup instructions on page 1-23.
3. Leave transmission selector in “neutral” for the pump to be ready to operate without churning.
4. Repeat steps 4 through 6 for placing pump in gear.

**NOTE:** When arriving at a structure fire or on occasion where the tower is not immediately needed, but the fire pump is being used, place the PTO in gear and deploy the ground stabilizer before placing the fire pump in gear. Then, if the need to use the tower arises while the fire pump is being used, the stabilizers are set, and the tower will be ready for immediate use. If the PTO is not engaged before the pump is set up, then slow the engine to idle before engaging PTO.



### **CAUTION**

*Attempting to place the PTO in gear with the pump in gear will result in serious damage to the PTO and transmission—unless engine speed is at an idle of approximately 700 RPM's.*

## 1.8 Aerial Setup Procedures

1. Leave transmission in neutral.
2. Set parking brake.
3. Engage PTO at engine idle.
4. Check the inclinometer and verify the truck is level within the safe operating range.



## WARNING

*The maximum side-to-side setup angle is 6 degrees, either direction.*

5. Place the wheel chocks approximately 3” in front of and behind the rear tires.
6. Pull out operator’s step.
7. Set up ground pads and stabilizers by pressing the “LOWER” control switch (Figure 2).



Figure 2

This is located near the control box, on the vertical face of the compartment adjacent to the pump panel. This will engage the engine at high speed until the jacks are all the way down. Then, ensure that both locks are in place.



## DANGER

*Power lines should always be observed and always avoided.*



## WARNING

*The aerial device is rated for service in winds up to 35 mph.*

**Operator Manual**

The aerial is now ready for operation. The automatic jack locks should have engaged, and hydraulic power diverted to the aerial controls. (Figure 3).



**Figure 3**

The aerial ladder must be operated with respect, discretion, and proper training. The aerial ladder should be operated at low speed when there is any danger, including electric wires, buildings, at close operations, returning to the cradle, and during operation around the cab. When the aerial is returned to the cradle and the “Jack Release” switch is activated a hydraulic valve will transfer power from the aerial to the jacks, locking out the aerial ladder functions and allowing jack operation.



**DANGER**

*Always place pads under the stabilizers to ground the truck in the event the tower comes into contact with powerlines. Failure to do so could result in serious injury or death.*



**DANGER**

*Operator must ensure that automatic locks on stabilizers are engaged.*



## **DANGER**

*Operator must always stand on the operator's step to help prevent operator from becoming the ground in the event the tower comes into contact with powerlines. Failure to do so could result in serious injury or death.*

8. Switch On the “Upper Power” and “Bucket Power” (if equipped) switches.

**NOTE: All operating controls at the turntable are hydraulic.**

**All operating controls at the platform are electric.**

**The “Upper Power” switch controls: lighting, intercom (if equipped) and rung alignment light.**

9. Verify with all personnel that the tower is ready to operate. When the stabilizers and ground pads are properly set on stable ground, the tower is designed to operate at optimum operational height and horizontal reach with rated payload. Always operate the tower with caution so it does not strike the cab or any other portion of the truck.

## **1.9 Stabilizing System**



## **DANGER**

*Never operate the tower without first deploying the stabilizer jacks with proper ground pads beneath them.*



## **DANGER**

*At all times, the ground operator must be at the controls, standing on the slide out step for safe operation.*

**Operator Manual**

The ground stabilizers of the underslung design consist of an outrigger with an inner and outer tube and a down jack hydraulic cylinder. The inner tube extends out from the outer tube of the stabilizer; this assembly is angled down to the ground by the jack cylinder, for a total span of 16 feet.

Operate the stabilizers by depressing the lower switch, adjacent to the driver side pump panel.



## **DANGER**

*Always place metal pads under stabilizers to ground the truck in the event the tower comes in contact with powerlines. Failure to do so could result in serious injury or death.*

### **1.10 Ladder Function Controls**

#### **Elevation**

The ladder can be elevated from minus 5 degrees to plus 75 degrees from the horizontal while in any position given that no obstructions, such as the body or cab, are present.

Raise the tower by pulling the right lever, located at the control box, outward.

Lower the tower by pushing the right lever, located at the control box, inward.

**NOTE: Controls on the platform (if equipped) are duplicates of lower controls.**

**NOTE: When moving the ladder from the cradle, the first motion of the ladder should be "RAISE". This should continue until the ladder is well above the apparatus.**



## **DANGER**

*When raising the tower, extreme caution must be used near powerlines. The operator must see the tower structure from the base to top to make sure the tower is clear.*

**NOTE: Make sure the tower has cleared the truck body, cab, and lights before rotating. The recommended procedure for tower operation is a slow, steady movement of the control lever. This will produce a smooth tower operation.**



## CAUTION

*Rapid movement of the control levers will result in rough jerking of the tower. This will create excessive loading on the tower structure. This kind of operation is unsafe and will lead to premature wear and possible structure failure.*

The tower can be elevated from minus 4 degrees to plus 75 degrees from horizontal while in any position that does not cause an interference with the body or cab.

### Extend and Retract

Extend the tower by pushing the left control lever away from you.

Retract the tower by pulling the left control lever toward you.



## WARNING

*The aerial device is rated for service in winds up to 35 mph.*

### Rotation

Rotate the tower clockwise by pushing the center control lever away from you.

Rotate the tower counterclockwise by pulling the center control lever toward you.

The tower can rotate a continuous 360 degrees either to the left or to the right.

### High Speed Control

A "High-Speed" foot switch is located on the pump panel running board. (Figure 4) This switch increases the engine speed and hydraulic pressure at the same time. The speed of any operation of the tower can be increased with this switch.



## CAUTION

*Use caution when using the high-speed switch.*

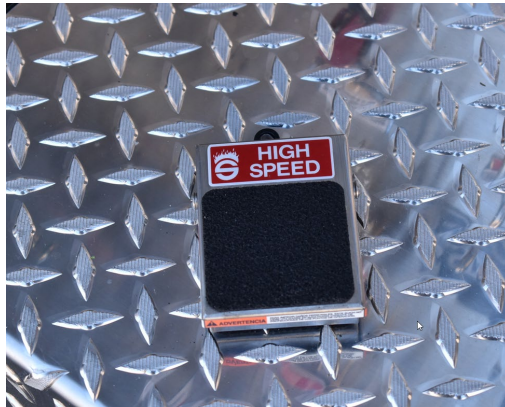

**Figure 4**

**NOTE:** Before engaging the "High-Speed" switch, the operations control levers must be in the neutral position. When coming off "High-Speed", release the switch, then release the control lever to complete movement. This will give a smooth and safe operation.

When extending the tower and using the "High-Speed" control, release the "High-Speed" switch before reaching maximum extension. Tower extension will stop at maximum extension of the tower. (There is no signal device for indicating full extension.)

When retracting the tower and using the "High-Speed" switch, the same procedure applies to the use of the "High-Speed" control. Make sure to release the "High-Speed" switch before reaching a fully retracted position.

The tower can rotate a continuous 360 degrees to the left or right. Use the "High-Speed" switch if it is necessary to rotate the tower at a faster speed.

The rotation control lever must be engaged before engaging the "High-Speed" switch. When coming off "High-Speed", release the "High-Speed" switch before releasing the rotational control lever. This will give a smooth operation. **WHILE ROTATING THE TOWER, THE OPERATOR SHOULD NOT CHANGE DIRECTIONS BEFORE THE TOWER COMES TO A COMPLETE STOP!** If the operator





accidentally changes rotation direction with the tower not coming to a complete stop, a built-in relief valve is provided to reduce the shock. However, in no way should this be an operational practice!

## Auxiliary Motor Switch

**NOTE:** The auxiliary motor switch is to be used for service purposes only to place the ladder back into cradle and to raise the jacks it is not to be used for normal operations.

The auxiliary motor switch is located behind the flip-down access panel below the aerial control station. Use the auxiliary motor switch if a main hydraulic pump fails or if the truck engine fails. The auxiliary power is an electric motor, operating from the truck battery system which operates the auxiliary hydraulic pump.

Operate the motor by activating and holding the momentary AUX. MOTOR switch. (Figure 5)

All tower and outrigger functions can be operated on auxiliary power.



## CAUTION

*Prolonged operation of the auxiliary hydraulic motor could cause it to overheat. Operate for no longer than 10 minutes at a time to avoid overheating and burning out the motor. If the motor becomes hot, shut down and allow it to cool. Failure to do so could result in serious damage to the motor.*



Figure 5

## 1.11 Safety Interlock System

The safety interlock system prevents operating the tower until the stabilizers are properly set. The system is an electric hydraulic locking device. When the stabilizers are properly set, hydraulic power is transferred to the aerial controls.

To operate, place the PTO in gear according to the instructions in the cab. To operate the aerial properly, pull out the step at the pump panel. Depress the “LOWER” switch, until the jacks are completely out and down, and the jack lock is in position.

The aerial is now ready for operation. The hydraulic transfer valve should have shifted from jack to aerial position, allowing the controls to operate the aerial ladder. The aerial ladder must move on low speed when there is any danger, such as electric wires, buildings, at close operations, returning to the cradle, and during operation around the cab. Return the aerial to the cradle and push the "Jack Release" switch. The hydraulic circuit will transfer, locking out the aerial ladder functions and allowing jack operation. The aerial ladder must be operated with respect, discretion, and proper training.



### **WARNING**

*The stabilizers must be visually checked by the operator or a designated person to make sure the stabilizers and pads are properly set.*

### **Interlock Jack Release**

The safety interlock system is provided with a “Jack Release” switch. (Figure 7)



Figure 7



## **DANGER**

*Never operate the tower unless the stabilizers and pads are properly set.*

When activated, the “Jack Release” switch transfers operation to the stabilizers. Use this switch only when operations are complete, and the ladder is back in the cradle.

### **1.12 Waterway and Nozzle Operation**

The waterway through which water from the pump is transferred to the nozzle is a four (4) section telescopic aluminum device. This device is located within the tower sections, mounted, and cushioned to eliminate any undue stress or strain under tower operating conditions.

The waterway is fed from the pump through the main feed line. It comes up through the turntable and passes through a large, stainless steel flex tube which is directly attached to the waterway. Special packing gland seals are provided at the attachment location of each waterway section to assure constant alignment and eliminate wear to the tubes.

The feed line for the waterway is provided through a ball valve at the lower entrance of the water supply. This is to make sure no undue water surge is applied to the waterway.

▽ **Operator Manual**

A relief valve is installed in the waterway system to help prevent excessive pressure in the waterway. Should the operator retract the tower without opening the waterway drain or should pump pressure exceed the capacity of the waterway, the relief valve will open. Do not exceed 250 PSI discharge pressure. The waterway drain should always be **left 50% open** when tower is not being operated along with all nozzles and valves.

Maintenance is minor and is described in the section under lubrication.

**NOTE: Before retracting the tower, make sure the nozzle and the waterway drain are open to avoid compressing the water in the waterway. Failure to do so can result in serious damage to the waterway.**

**NOTE: These steps must be followed in the above order to completely drain waterway and all nozzles. This will prevent freezing the waterway in cold weather and damaging the waterway when retracting.**

### **1.13 Platform Mounting and Leveling System**

At all times, the platform must be maintained in a level position relative to the turntable. This is accomplished by a self-contained electrical system.

#### **Disabling Electro-Hydraulic Bucket Leveling**

The temporary leveling disable switch will stop the leveling system from reacting to the movements of the operator. This switch's function will be overridden under two conditions:

1. The joysticks are manipulated in any way (Rotate, Retract, Etc.)
2. The operator causes a sufficient disturbance to the inclinometer.

There is a range, near level with the ground, where movements inside the bucket will be ignored, but if any movements by the operator cause the platform level to get outside of that range, the leveling system will be re-enabled automatically.



The E-Stop has no such conditions. If the E-stop is pressed, the electric leveling system control will be disabled until the E-Stop switch is disengaged. (Figure 8)



Figure 8

## Manual Leveling Override



### **WARNING**

*The manual leveling system should only be used in the case of an electric and/or hydraulic failure occurs.*

A manual emergency override is provided in the leveling system. Should the leveling system not function for any reason, two valves are located at the end of the boom on the yoke side plate directly behind the platform (Figure 9). By opening these valves, fluid is permitted to flow freely from one side of the leveling cylinder piston to the other. The weight in the platform and the pendulum effect of the platform will keep the platform level.



Figure 9

## **1.14 Optional Breathing Air System**

If a life support breathing system is installed on the aerial tip. This system has an air cylinder mounted in brackets on the ladder turntable, a shut-off valve, and a constant flow air regulator.

Air is piped from the regulator by a heavy-duty air hose through an air reel, located in the base section of the tower.

At the tip of the aerial or in the platform (if equipped), there are air connections available to connect fire department breathing air apparatus.

Air to the connections can be regulated from the air supply cylinder by presetting the regulator at approximately 80 PSI. Once the air pressure is regulated, as required by the operator, turn the air on at the air cylinder valve to provide air to the tip.

The air valve should always be turned off when not in use. An air drain valve is provided on the bottom of the filter and should periodically be opened briefly to expel any moisture that may be captured in the filter. Use of the air system should be determined by the personnel using the aerial device.



## 1.15 Platform Anchorage System

### SUTPHEN TOWERS

4 Occupants when Dry (1000# tip load)  
3 Occupants when Flowing (750# tip load)

Travel Restraint System – Belt, Hook, 450 lbs. Anchorage Point  
One occupant per Anchorage Point

#### HOW TO USE

Position Belt at mid hip – adjust to a snug fit  
Attach Hook to Belt D-ring  
Attach Hook to Anchorage Point

#### NOTE -

##### Work Zone Inspections

Drop offs/Holes/Unstable Surface  
Inadequate Ceiling Height/Overhead Obstructions  
Slopes/Ditches/Bumps  
Debris and Floor Obstructions  
Overhead Electrical Lines (stay 20 feet away)  
Other Worker Locations  
Weather – Lightning/High Winds/Ice

##### Work Zone Stability

Set apparatus brakes  
Set outriggers on pads/solid, level surface  
Use wheel chocks when necessary  
Set out work zone warnings/cones when necessary

##### Fall Protection

Do not exceed load-capacity limits  
Use a restraining belt attached to anchorage point  
Ensure access gates are closed  
Stand firmly on floor of platform  
Do not climb on or lean on handrails

#### POSITIONING BODY BELT



#### HOOK



#### ANCHORAGE POINTS

One pair-each side

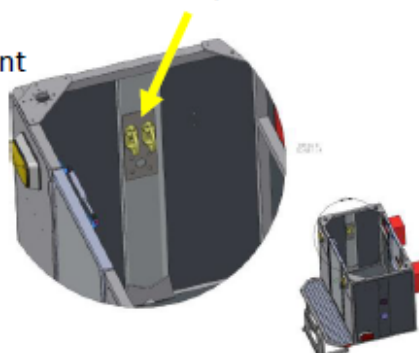

HPE-1019-1 SP70 PLATFORM ANCHORAGE SYSTEM

Reference NFPA 1901 2016 19.7

Purchase items meet or exceed all applicable OSHA / ANSI standards

## 1.16 Return Aerial to Travel Position

### Retract the Tower

Retract the tower fully by pulling the left control lever, located at the control box, toward you.



### **CAUTION**

*If the waterway has been used before retracting the tower, the nozzle and waterway drains must be open to avoid compressing the water in the waterway. Allow enough time for the waterway to drain before retracting the tower. Failure to do so can result in serious damage to the waterway.*

### Rotate the Tower

To rotate the tower to the right (clockwise), push the center control lever, located at the control box, away from you. To rotate the tower to the left (counter-clockwise), pull the control lever toward you. To store the aerial, rotate the tower until it is properly aligned to lower into the cradle.

**NOTE:** The trucks are equipped with an alignment indicator. This indicator is part of the graphic screen on the pedestal. It will light when the tower is in position to come down directly in the middle of the support cradle.

**Aerial towers are also equipped with alignment arrows. One arrow is affixed to the turntable and the other arrow is affixed to the tread plate deck. They are located at the outer rim of the turntable, adjacent to the control station.**

**Rotate the tower until the points of both arrows align. The tower is now in position to lower into the support cradle.**

[www.sutphen.com](http://www.sutphen.com)





---

## Lower the Tower

**NOTE:** This function should only be performed with the engine speed at idle.

Lower the ladder fully by pushing the right control lever away from you. After the tower is lowered into the cradle, continue to hold the control lever in the lower position for a few seconds. This will pressurize the lift cylinders in the “down” direction. The holding valves in the cylinders will maintain this pressure, effectively locking the ladder in the cradle for travel.

Turn off “UPPER POWER”

**NOTE:** The trucks are equipped with an alignment light. This light is an amber light located at the left front corner of the hose bed. It will light when the tower is in position to come down directly in the middle of the support cradle.

Aerial towers are also equipped with alignment arrows. One arrow is affixed to the turntable and the other arrow is affixed to the treadplate deck. They are located behind the control box.

Rotate the tower until the points of both arrows align. The tower is now in position to lower into the support cradle.

After the tower is lowered into the cradle, continue to hold the control lever in the lower position for a few seconds.

Release the lever to permit a pilot check valve in the hydraulic circuit to trip and lock at its present pressure. This locks the tower in the cradle for travel.



## CAUTION

*Lower the aerial at engine idle only, do NOT use the high-speed switch while lowering.*

## Remove Wheel Chocks

**NOTE:** Always remove the wheel chocks before releasing the stabilizers. Failure to do so could result in wedging the chocks tightly against the tires making them unremovable. Remove safety pins on stabilizers.

**Warranty Manual**

## Retract the Stabilizers

1. Activate switch marked “Jack Release” at the driver side pump panel.
2. Retract the stabilizers by depressing the “Raise” switch, located near the control station, until jacks are fully retracted.
3. Stow the operator’s step.
4. Turn the switches marked “Upper Power” and “Bucket Power” (if equipped) off.
5. Enter the cab and disengage the fire pump, if used.
6. Shift transmission to neutral.
7. Wait until speedometer registers “0” miles per hour.
8. Move pump shift lever from “Pump” position to “Road” position.
9. Disengage the PTO switch from “in” to “out” position. Make sure the green pilot light goes out.
10. Release the parking brake.
11. Place transmission in appropriate gear (Drive 1-4 or Reverse).



## CAUTION

*Before driving away, the operator should make a quick inspection around the truck to make sure all tools and appliances have been removed and stowed, compartment doors closed, and the vehicle is unobstructed.*

*Operator must also check the four (4) warning lights above the windshield marked “Cab Door Open”, “Comp’t Door Open”, “Outrigger Out”, and “Outrigger Down”, to make sure they are not lighted.*



## WARNING

*All personnel must be seated, and seat belts fastened before the unit is moved.*



## WARNING

*Never back the truck unless a guide has been placed at the rear of the truck, giving clear signals to the operator. If the guide disappears from view, the movement must be stopped until the guide appears.*



## Chapter 2 Maintenance Manual

	<u>Page</u>
2.1 Aerial Maintenance .....	2-1
<i>Stabilizers</i> .....	2-1
<i>Main Lift Cylinders</i> .....	2-1
<i>Pivot Shaft Bearings</i> .....	2-1
<i>Turntable Bearing</i> .....	2-1
<i>Rotation Gear Reducer</i> .....	2-2
<i>Drive Gears</i> .....	2-3
<i>Tower Extension/Retraction Cylinder</i> .....	2-3
<i>Sheaves and Cables</i> .....	2-3
2.2 Extension System.....	2-4
<i>SL75 Cable Adjustment Procedure</i> .....	2-4
<i>SA75 Cable Adjustment Procedure</i> .....	2-7
<i>SP70 Cable Adjustment Procedure</i> .....	2-11
<i>Slide Blocks</i> .....	2-15
<i>Waterway and Seals</i> .....	2-15
2.3 Water Lubrication Procedure.....	2-16
<i>Waterway Nozzle</i> .....	2-16
<i>Platform Mounting and Leveling System</i> .....	2-17
<i>Hydraulic Oil Tank</i> .....	2-18
<i>Hydraulic Tank Fill Instruction</i> .....	2-19
2.4 High Pressure Filtration System.....	2-20
2.5 Maintenance of Structure.....	2-20
<i>Aluminum Tower Structure</i> .....	2-20
<i>Turntable Attachments</i> .....	2-21
<i>Attachment of Support Structure to Truck Frame</i> .....	2-21
<i>Aerial Tower and Ice Build Up</i> .....	2-22
<i>Aerial Tower Lubrication and Maintenance Schedule</i> .....	2-24
<i>Torque Specifications</i> .....	2-25
<i>Walk Around Checks for Mobile Fire Apparatus</i> .....	2-30
<i>Draining &amp; Winterizing Trucks</i> .....	2-35



---

## 2.1 Aerial Maintenance

### Stabilizers

When the stabilizers are extended completely to the ground, an area of the inner sleeve becomes exposed. This exposed area also comes in contact with the inside surface of the outer tube. This area should be periodically coated with a light film of grease. Visually check jack locks. Lubricate grease fittings on each jack cylinder with Pro-One EP-2 Grease, and air lock cylinders with air lubrication oil.

### Main Lift Cylinders

The main lift cylinders are located on each side of the main base section of the tower assembly. Each cylinder has two (2) lube points. One (1) lube point is on the rod end where the rod eye attaches to the side plate of the tower assembly. One (1) lube point is on the bottom end where the cylinder is attached to the turntable. At each point, a grease fitting is installed. These points should be lubricated with Pro-One EP-2 Grease every 25 hours of operation, or annually, whichever comes first.

### Pivot Shaft Bearings

There are two (2) pivot shaft bearings located on top of the upper assembly side plates, one on each side, which rotate on the pivot shaft. The pivot shaft is permanently attached to turntable side plates on the outside of the side plates. Grease fittings are installed on the pivot shaft bearings. These bearings need to be lubricated with Pro-One EP-2 Grease every 25 hours of operation, or annually, whichever comes first.

### Turntable Bearing

The bearing and drive gear assembly are located directly under the turntable. The entire turntable and tower assembly rotates on this bearing. This bearing is pre-lubricated at the factory with a Pro-One EP2 Grease. Grease fittings are provided on the inside of the bearing accessible

▼ **Maintenance Manual**

through the top of the upper assembly. Lubrication should be done three (3) months after delivery, then annually. Use Pro-One EP-2 Grease.

**NOTE: At this time, we recommend all bolts attaching the turntable to the bearing, and all bolts attaching the bearing to the mainframe (where applicable) be checked for tightness.**

### **Rotation Gear Reducer**

This device rotates the turntable and tower assembly. It is attached to the lower assembly, below the gear, on the left side of the assembly.

It is driven by a hydraulic motor, directly attached to the high-speed worm gear shaft. No lubrication is required for the hydraulic motor. On the main gear case, there are three (3) plugs, located on the right-handout board side. The top plug is the oil fill vent plug. The one on the side is the fill level plug. The bottom one is the drain plug.

Under normal tower operation conditions, the lube oil in this gear reducer needs to be changed three (3) months after the delivery date of the tower. Thereafter, lube oil needs to be changed every 12 months (average 4 hours per day operation). Never over fill the unit. Check oil level every three (3) months. Use a good grade of 140 weight gear lube oil. At the upper portion of the main gear case, there is a grease fitting. This fitting needs to be greased every 25 hours of operations, or annually, with Pro-One EP-2 Grease.

There are three (3) plugs on the primary rotation gear housing. The one on top (1/4") is the filler-breather plug. The one on the side (1/4") is the lube level plug. The one in the bottom of the high-speed gear housing (1/4") is the drain plug.

Maintain oil level to Oil Level plug. Check oil level every three (3) months. Use a good grade of 140 weight gear lube oil.

**NOTE: Access to the rotation gear reducer is gained by removing the access panels adjacent to the turntable access ladder.**



---

## **Drive Gears**

The drive pinion gear and the turntable bearing gear are lubricated with a special elastic lube, designed to endure the life of the unit.

## **Tower Extension/Retraction Cylinder (Model SL75 only)**

Located on each side of the ladder base section, is a cylinder which extends and retracts the ladder assembly. There are two points on each of these cylinders that require lubrication. One is at the base end, nearest the turntable, the other is at the tip end, where the rod eye attaches to the next section. These need to be lubricated two (2) times a year. Use Pro-One EP-2 Grease. At each end of the cylinder, there are bolts attaching the cylinder to the tower. These bolts need to be checked every three (3) months for tightness.

## **Sheaves And Cables**

There are sheaves and cables which are part of the tower extension/retraction system from the second section up. Each sheave has a bearing and requires periodic lubrication. In the sheave bearing pin, there is a grease fitting provided. Each sheave needs to be greased every 25 hours of service, or annually. Use Pro-One EP-2 Grease.

When servicing the cables, the tower should be extended horizontally to maximum position, and the cables wiped free of any dirt and/or grime with a damp naphtha cloth. The cables then need lubricated with a thin film of Vitalife 400 or LPS Chain Mate.

▼ **Maintenance Manual**



**DANGER**

*Stabilizers must be set before performing this operation.*



**DANGER**

*If any strand of the cable is fractured or damaged, immediately lower the aerial and retract slowly. Remove from service until repaired.*

## 2.2 Extension System

### SL75 Cable Adjustment Procedure

Before beginning cable adjustment, be aware that this adjustment not only affects the tension of the cables, but also the position of the ladder section rungs. Follow the steps outlined below to maintain alignment throughout all sections as the cables are adjusted.

1. Set up aerial device according to the operator's manual. Make sure the waterway is empty and there is no extra weight on the aerial.
2. When the rung alignment indicator is illuminated, these rungs will always be aligned. Higher aerial sections, however, rely on proper cable adjustment to maintain alignment.
3. Raise the aerial to 45 degrees and rotate to one side of the apparatus. Position the aerial at, or slightly above zero degrees, so the cables below rung level can be serviced from the ground. With the aerial fully retracted, measure the gaps between each aerial section. The gap between Sections 1 and 2 is set by the cylinder connection and cannot be adjusted. Make sure there is a gap of ¼"-2" between sections two and three. Between the third and fourth sections, this gap should be between 5 ½"-6 ¼". If you do not have the required spacing, then make the following adjustments.
  - a. Fully extend the aerial. Be sure the aerial tip does not touch the ground.
  - b. Measure the distance between sections 2-3 and 3-4. It should be





---

176 inches (+/-1/2) for model SL75.

- i. If it is less than 175½"-Loosen the retract cables. To loosen the cables, you must first loosen the cable rod lock nut, and then loosen the adjustment nut. Retract the aerial approximately 12 inches to release tension from the extend cables. Tighten the extend cables. Repeat this process as necessary to achieve the prescribed dimension on all sections. Retighten all lock nuts, then fully retract the ladder and re-check the spacing between the sections.
  - ii. If it is greater than 176½"-Retract the ladder approximately 12 inches, then loosen the extend cables. To loosen the cables, you must first loosen the cable rod lock nut, and then loosen the adjustment nut. Extend the aerial completely, then tighten the retract cables. Repeat this process as necessary to achieve the prescribed dimension on all sections. Retighten all lock nuts, then fully retract the ladder and re-check the spacing between the sections.
  - c. Once the proper spacing is achieved, proceed with the adjustment procedure.
4. Assure the aerial slide areas and the waterway are clean and well-lubricated.
  5. Inspect all cables for kinks, wear, and any signs of damage. Lubricate cables and sheaves. Extend and retract ladder as needed to reach all components.
  6. Fully extend ladder, keeping the tip clear of the ground. Make a mark on the 2<sup>nd</sup> ladder section, 24 inches from the base section. Retract the ladder 24 inches, until the mark is at the edge of the base section.
  7. Measure to the center of exposed length of the 2<sup>nd</sup> section approximately 76 inches from the base section and make a mark. At this mark, measure the distance from the bottom of the aerial section to the top of each cable.

▼ **Maintenance Manual**

The measurement should be taken with the cable hanging free, without pulling down on it. Both measurements should be 11/16 inch (+/-1/8inch), and the pair should be equal. If not, adjust the cables as follows.

- a. Loosen the cable rod locknut and tighten or loosen the adjusting nuts, retighten the locknut. With the lock nut re-secured, if more than 2" of cable rod end is exposed, contact the factory service department before proceeding.
8. Measure to the center of the 3<sup>rd</sup> section, approximately 76 inches from the base section and make a mark. At this mark, measure the distance from the bottom of the aerial section to the top of each cable. The measurement should be taken with the cable hanging free, without pulling down on it. Both measurements should be 7/8inch (+/-1/8 inch), and the pair should be equal. If not, adjust the cables as follows.
- a. Loosen the cable rod locknut and tighten or loosen the adjusting nuts, retighten the locknut. With the lock nut re-secured, if more than 2" of cable rod end is exposed, contact the factory service department before proceeding.

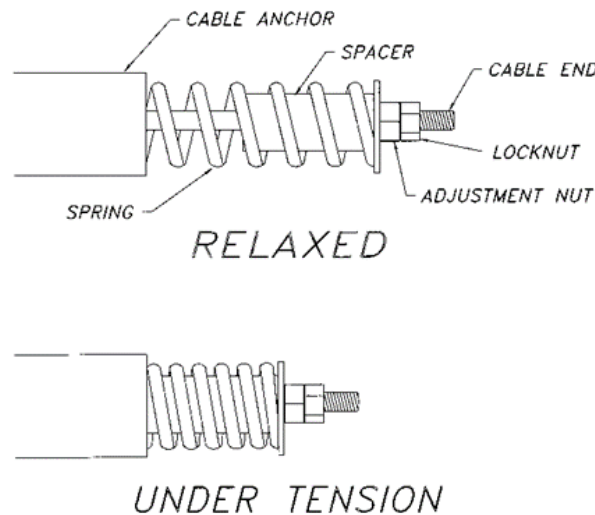

8. Operate the ladder throughout the extend and retract strokes. (Remember there will always be some slack in the cables not doing the work of the function performed. i.e., there will be slack in the retract cables when extending the ladder.)



10. Stop the ladder when the rung alignment indicator illuminates. Check the position of the third ladder section rung alignment. If the third section rungs are running behind the second section rungs, the third section retract cables should be loosened and extend cables (which hang below the second aerial section) tightened. Adjust as necessary. Be sure the third section rung position is satisfactory before moving on to the fourth section.
11. Again, operate the ladder throughout the extend and retract strokes. Stop the ladder when the rung alignment indicator illuminates. Check the position of the fourth ladder section rung alignment. If the fourth section rungs are running behind the third section rungs, the fourth section retract cables should be loosened and extend cables (which hang below the third aerial section) tightened. Adjust as necessary.
12. When adjustment is complete, operate the ladder throughout the extend and retract strokes at different angles of elevation
  - a. It is important to remember there will always be a certain amount of slack in the cables, not pulling the ladder sections. At high angles of elevation, the extend cables will always have tension, even while retracting the ladder.
  - b. The ladder sections should move smoothly, with all sections moving simultaneously. Sections should not drift back when the ladder is elevated, beyond the compression of the tensioning springs. At no time should the sections collide while retracting.
13. With the aerial fully retracted, recheck spacing gaps between sections.

### **SA75 Cable Adjustment Procedure**

Before beginning cable adjustment, be aware that this adjustment not only affects the tension of the cables, but also the position of the ladder section rungs. Follow the steps outlined below to maintain alignment throughout all sections as the cables are adjusted.

**Maintenance Manual**

1. Set up aerial device according to the operator's manual. Make sure the waterway is empty and there is no extra weight on the aerial.
2. When the rung alignment indicator is illuminated, these rungs will always be aligned. Higher aerial sections, however, rely on proper cable adjustment to maintain alignment.
3. Raise the aerial to 45 degrees and rotate to one side of the apparatus. Position the aerial at, or slightly above, zero degrees, so the cables below rung level can be serviced from the ground. With the aerial fully retracted, measure the gaps between each aerial section. The gap between Sections 1 and 2 is set by the cylinder connection and cannot be adjusted. Make sure there is a gap of ¼"-1" between sections two and three. Between the third and fourth sections, this gap should be between 1"-2". If you do not have the required spacing, then make the following adjustments.
  - a. Fully extend the aerial. Be sure the aerial tip does not touch the ground.
  - b. Measure the distance between sections 2-3 and 3-4. It should be 177 inches (+/-1/2) for model SA75.
    - i. If it is less than 176 ½"-Loosen the retract cables. To loosen the cables, you must first loosen the cable rod lock nut, and then loosen the adjustment nut. Retract the aerial approximately 12inches to release tension from the extend cables. Tighten the extend cables. Repeat this process as necessary to achieve the prescribed dimension on all sections. Retighten all lock nuts, then fully retract the ladder and re-check the spacing between the sections.
    - ii. If it is greater than 177 ½"- Retract the ladder approximately 12 inches, then loosen the extend cables. To loosen the cables, you must first loosen the cable rod lock nut, and then loosen the adjustment nut. Extend the aerial completely, then tighten the retract cables. Repeat this process as necessary to achieve the prescribed dimension on all sections. Retighten all lock nuts, then fully retract the ladder and re-



check the spacing between the sections.

c. Once the proper spacing is achieved, proceed with the adjustment procedure.

4. Assure the aerial slide areas and the waterway are clean and well-lubricated.
5. Inspect all cables for kinks, wear, and any signs of damage. Lubricate cables and sheaves. Extend and retract ladder as needed to reach all components.
6. Fully extend ladder, keeping the tip clear of the ground. Make a mark on the 2nd ladder section, 24 inches from the base section. Retract the ladder 24 inches, until the mark is at the edge of the base section.
7. Measure to the center of the 2nd section approximately 76 1/2 inches from the base section and make a mark. At this mark, measure the distance from the bottom of the aerial section to the top of each cable. The measurement should be taken with the cable hanging free, without pulling down on it. Both measurements should be 1 inch (+/- 1/8 inch), and the pair should be equal. If not, adjust the cables as follows.
  - a. Loosen the cable rod locknut and tighten or loosen the adjusting nuts, retighten the locknut. With the lock nut re-secured, if more than 2" of cable rod end is exposed, contact the factory service department before proceeding.
8. Measure to the center of the 3rd section, approximately 76 1/2 inches from the base section and make a mark. At this mark, measure the distance from the bottom of the aerial section to the top of each cable. The measurement should be taken with the cable hanging free, without pulling down on it. Both measurements should be 7/8 inch (+/- 1/8 inch), and the pair should be equal. If not, adjust the cables as follows.
  - a. Loosen the cable rod locknut and tighten or loosen the adjusting nuts, retighten the locknut. With the lock nut re-secured, if more than 2" of cable rod end is exposed, contact the factory service department before proceeding.

**Maintenance Manual**

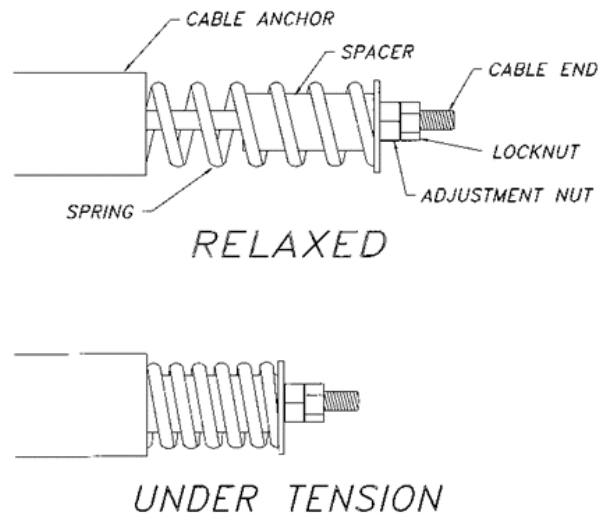

9. Operate the ladder throughout the extend and retract strokes. (Remember there will always be some slack in the cables not doing the work of the function performed. i.e., there will be slack in the retract cables when extending the ladder.)
10. Stop the ladder when the rung alignment indicator illuminates. Check the position of the third ladder section rung alignment. If the third section rungs are running behind the second section rungs, the third section retract cables should be loosened and extended cables (which hang below the second aerial section) tightened. Adjust as necessary. Be sure the third section rung position is satisfactory before moving on to the fourth section.
11. Again, operate the ladder throughout the extend and retract strokes. Stop the ladder when the rung alignment indicator illuminates. Check the position of the fourth ladder section rung alignment. If the fourth section rungs are running behind the third section rungs, the fourth section retract cables should be loosened and extend cables (which hang below the third aerial section) tightened. Adjust as necessary.
12. When adjustment is complete, operate the ladder throughout the extend and retract strokes at different angles of elevation.



- 
- a. It is important to remember there will always be a certain amount of slack in the cables, not pulling the ladder sections. At high angles of elevation, the extend cables will always have tension, even while retracting the ladder.
  - b. The ladder sections should move smoothly, with all sections moving simultaneously. Sections should not drift back when the ladder is elevated, beyond the compression of the tensioning springs. At no time should the sections collide while retracting.
13. With the aerial fully retracted, recheck spacing gaps between sections.

### **SP70 Cable Adjustment Procedure**

Before beginning cable adjustment, be aware that this adjustment not only affects the tension of the cables, but also the position of the ladder section rungs. Follow the steps outlined below to maintain alignment throughout all sections as the cables are adjusted.

1. Set up aerial device according to the operator's manual. Make sure the waterway is empty and there is no extra weight on the aerial.
2. When the rung alignment indicator is illuminated, these rungs will always be aligned. Higher aerial sections, however, rely on proper cable adjustment to maintain alignment.
3. Raise the aerial to 45 degrees and rotate to one side of the apparatus. Position the aerial at, or slightly above zero degrees, so the cables below rung level can be serviced from the ground. With the aerial fully retracted, measure the gaps between each aerial section. The gap between Sections 1 and 2 is set by the cylinder connection and cannot be adjusted. Make sure there is a gap of 0"-1" between sections two and three. Between the third and fourth sections, this gap should be between 1"-2". If you do not have the required spacing, then make the following adjustments.

**Maintenance Manual**

- a. Fully extend the aerial. Be sure the aerial tip does not touch the ground.
  - b. Measure the distance between the ends of sections 2-3 and the ends of sections 3-4. It should be 144" (+/-1/2) for model SP70.
    - i. If it is less than 143 1/2"-Loosen the retract cables. To loosen the cables, you must first loosen the cable rod lock nut, and then loosen the adjustment nut. Retract the aerial approximately 12inches to release tension from the extend cables. Tighten the extend cables. Repeat this process as necessary to achieve the prescribed dimension on all sections. Retighten all lock nuts, then fully retract the ladder and re-check the spacing between the sections.
    - ii. If it is greater than 144 1/2"- Retract the ladder approximately 12 inches, then loosen the extend cables. To loosen the cables, you must first loosen the cable rod lock nut, and then loosen the adjustment nut. Extend the aerial completely, then tighten the retract cables. Repeat this process as necessary to achieve the prescribed dimension on all sections. Retighten all lock nuts, then fully retract the ladder and re-check the spacing between the sections.
  - c. Once the proper spacing is achieved, proceed with the adjustment procedure.
4. Assure the aerial slide areas and the waterway are clean and well-lubricated.
  5. Inspect all cables for kinks, wear, and any signs of damage. Lubricate cables and sheaves. Extend and retract ladder as needed to reach all components.
  6. Fully extend ladder, keeping the tip clear of the ground. Make a mark on the 2<sup>nd</sup> ladder section, 24 inches from the base section. Retract the ladder 24 inches, until the mark is at the edge of the base section.
  7. Measure to the center of the exposed length of the 2<sup>nd</sup> section, approximately 60 inches from the base section and make a mark. At this mark, measure the distance from the bottom of the aerial section to the top





of each cable. The measurement should be taken with the cable hanging free, without pulling down on it. Both measurements should be 1 inch (+/- 1/8 inch), and the pair should be equal. If not, adjust the cables as follows.

- a. Loosen the cable rod locknut and tighten or loosen the adjusting nuts, retighten the locknut. With the lock nut re-secured, if more than 2" of cable rod end is exposed, contact the factory service department before proceeding.
8. Measure to the center of the exposed length of the 3rd section, approximately 60 inches from the base section and make a mark. At this mark, measure the distance from the bottom of the aerial section to the top of each cable. The measurement should be taken with the cable hanging free, without pulling down on it. Both measurements should be 7/8 inch (+/- 1/8 inch), and the pair should be equal.

If not, adjust the cables as follows.

- a. Loosen the cable rod locknut and tighten or loosen the adjusting nuts, retighten the locknut. With the lock nut re-secured, if more than 2" of cable rod end is exposed, contact the factory service department before proceeding.

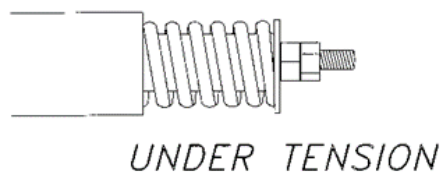
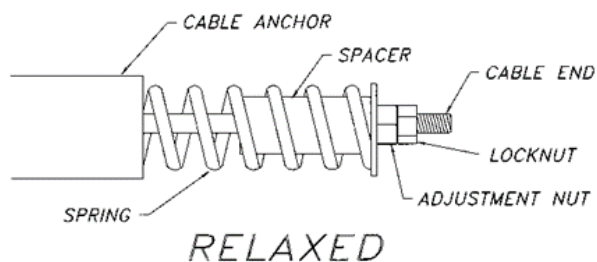

 **Maintenance Manual**

9. Operate the ladder throughout the extend and retract strokes. (Remember there will always be some slack in the cables not doing the work of the function performed. i.e., there will be slack in the retract cables when extending the ladder.)
10. Stop the ladder when the rung alignment indicator illuminates. Check the position of the third ladder section rung alignment. If the third section rungs are running behind the second section rungs, the third section retract cables should be loosened and extended cables (which hang below the second aerial section) tightened. Adjust as necessary. Be sure the third section rung position is satisfactory before moving on to the fourth section.
11. Again, operate the ladder throughout the extend and retract strokes. Stop the ladder when the rung alignment indicator illuminates. Check the position of the fourth ladder section rung alignment. If the fourth section rungs are running behind the third section rungs, the fourth section retract cables should be loosened and extend cables (which hang below the third aerial section) tightened. Adjust as necessary.
12. When adjustment is complete, operate the ladder throughout the extend and retract strokes at different angles of elevation
  - a. It is important to remember there will always be a certain amount of slack in the cables, not pulling the ladder sections. At high angles of elevation, the extend cables will always have tension, even while retracting the ladder.
  - b. The ladder sections should move smoothly, with all sections moving simultaneously. Sections should not drift back when the ladder is elevated, beyond the compression of the tensioning springs. At no time should the sections collide while retracting.
13. With the aerial fully retracted, recheck spacing gaps between sections.



---

## Slide Blocks

These devices are attached to the ends of the tower at both the upper and lower positions on each section. There are 24 slide blocks in the tower. They support each section of the tower, so no metal-to-metal contact occurs.

The material is UHMW-PE (ultra-high molecular weight polyethylene) compound. It is designed to withstand heavy loading. Lubrication is required in the path in which the slide blocks travel on each section. The slide block paths are lubricated at the factory with Prizm grease. The slide block path lubrication needs to be checked every 25 hours of operation, or annually. Any bare spots should be cleaned, and either Prizm or Pro-One reapplied.

There are exceptions to this schedule that should be considered. Should the tower be operated at a fire and exposed to excessive dirt and grime, it is recommended that the slide block travel paths be cleaned, and the lubricant be reapplied.

## Waterway and Seals

This is the telescopic tube device inside the tower which carries the water to the tower nozzle. It has seals which ride on the internal honed surface of the tubes. These seals are made with an impregnated lubricant. In cases when the tower is operated many times without pumping

water through the waterway, it is necessary to provide additional lubrication every 25 hours of aerial operation to the seals through the waterway with Shell V1002 Lithium Grease. The procedure is as follows:



### **DANGER**

*Never extend or move the tower in any way while persons are on the tower. The person oiling the waterway should wear a life belt while on the tower.*



### **DANGER**

*Stabilizers must be set before performing this operation.*

**Maintenance Manual**

This service should be done following any extensive use of the tower without pumping water, or monthly. The outsides of the tubes are provided with nylon bearing collar assemblies built into the mounting collar of each section. The outside of these tubes should be kept free of dirt and grime to protect the bearing collars.

Should the tower be used under extremely dirty conditions, the waterway should be wiped off promptly with Naphtha or similar solvent to assure that the surface of the tubes are free of abrasive particles.

## **2.3 Waterway Lubrication Procedures (Models SL75, SA75 & SP70—black waterways)**

1. Set up truck for tower operation.
2. Raise and rotate ladder off the side of truck.
3. Fully extend ladder out.
4. Use a clean towel and wipe off the outer sections of the waterway tubes.
5. Apply Shell V1002 Lithium Grease to a clean towel and wipe the grease on the entire length of each waterway tube, except for the main outside large tube.
6. Retract ladder fully and return ladder to cradle.

### **Waterway Nozzle**

**NOTE: Refer to Nozzle Manufacturer's instructions for more detailed information.**

The gears must be kept greased at all times. Pro-One EP2 grease should be applied to the grease fittings annually. Grease should be applied until visible through the swivel plugs.



---

## **Platform Mounting and Leveling System**

The platform is suspended in the yoke, anchored on each side with special self-alignment bearings and high tensile steel bolts. The bolts holding the bucket to the yoke have special locking devices to assure positive safe operation.

The platform is maintained in a level position relative to the turntable at all times. This is accomplished by a self-contained hydraulic system, eliminating any hydraulic lines up the tower.

To properly check hydraulic fluid level in the bucket leveling system, raise the ladder to full elevation. Shut off the upper power switch. Lower the ladder to horizontal position. Remove vent plug on reservoir tank and check, add if needed DexMerc (the hydraulic fluid). Raise the ladder, turn on the “UPPER POWER” switch and let the bucket level.

This system operates two (2) hydraulic cylinders which are attached to the platform supporting yoke and to the platform directly below the supporting pivot point of the platform. The attached pivot point of the platform is above the center line of the platform, providing pendulum effect, reducing extreme amounts of energy required to level the platform. The system is electrically activated and kept level during any function of the tower.

▼ **Maintenance Manual**

## Hydraulic Oil Tank

The tank, located under the left side rear cab entrance, has a capacity of 32 gallons. The hydraulic oil furnished in your aerial tower hydraulic system is filtered DexMerc hydraulic oil. Maintain the oil level to the mark on the dipstick attached to the tank cap. Any changes of or additions to the aerial hydraulic oil should be with Dexron III, filtered to at least ISO 22/18/13 cleanliness level. Un-filtered oil may accelerate wear and decrease performance of some components.



**Figure 10**



## CAUTION

*When checking or adding oil, make sure all hydraulic systems are at rest (retracted). Failure to do so will result in overfilling the system.*

The hydraulic oil filters should be changed after the first three (3) months of service and changed annually thereafter.

This is done as follows:

1. Shut off oil to filter at tank valve.
2. Remove the filter.
3. Inspect oil in the filter. Do this by using a piece of clear glass, a white cloth or piece of paper, and pouring some of the oil in the filter onto it. This way any dirt, filings, and moisture can be observed.
4. Replace the filter with the appropriate new filter.



**Figure 11**



## CAUTION

*There are two filters in the hydraulic system, one located in the reservoir lid (6 micron – MF1003A06HB) (see Figure 10) and one in the high-pressure portion of the system located under the rear of the cab (6 micron – HP1351A10AN) (Figure 11). Each must be replaced in kind. Failure to do so could result in damage to the hydraulic system or cause poor operation of the tower.*

5. After replacing the filters, turn the shutoff valves on.
6. Run the hydraulic system for 1 to 2 minutes to circulate oil through the filters.
7. Check the oil level and add oil to the proper level, if required.

**NOTE: All hydraulic cylinders and actuators, except cab lift, must be in the retracted position (i.e., travel position).**

### Hydraulic Tank Fill Instruction

**NOTE: Use only clean oil to fill reservoir.**

1. Raise cab to locate Hydraulic Reservoir.
2. Locate the Hydraulic Tank Fill port. (Figure 10)
3. Locate the Fill Level Dip Stick, this may be built into the fill port cap, on top of the Hydraulic Fluid Reservoir, which is located behind the driver's side front tire.
4. Check the current oil level. Proceed only if it is below the full level (line on dipstick). If it is at or above the full mark, the system is full. Replace the dipstick and return the cab to the travel position.
5. When the fluid level reaches the full level (approximately 2" from the top) replace the dipstick and fill port cap.
6. Return cab to stowed position.

## 2.4 High Pressure Filtration System

SP70, SL75 and SA75 fitted with KFS4596 reservoir assembly:

The return filter is fitted with a By-Pass indicator. Change this filter if the By-Pass indicator is going into the red. This must be observed when the unit is in operation. With the unit fully setup at high idle observe the By-Pass indicator when running retract and lower at the same time at high idle. This is the highest flow rate the filter will see. Otherwise change this filter after the 1st 50 hours of operation and 250 hours thereafter

Replace with MP Filtri original equipment element #HP1351A10AN. The KFS4596-C reservoir assembly is fitted with a dipstick. This reservoir is full when all stabilizers and the aerial stowed at 2-3" from the top of the tank. Hydraulic fluid should be replaced every 500 hours of operation or one year of operation, whichever comes first. Ensure the new hydraulic fluid is filtered to ISO code 22/18/13. New oil from the refinery or oil distributor that has not been filtered to this ISO code, it is typically 24/22/20.

## 2.5 Maintenance of Structure

### Aluminum Tower Structure

The tower structure members are #6061-T6 and #6005-T6 aluminum alloy extrusion. This alloy is very resistant to corrosion and requires very little maintenance. Periodic washing with clear water only is recommended. Use mineral spirits for removal of tar, oil, and smoke film. If a brighter appearance is desired, use any quality automotive polish, a mag and aluminum wheel cleaner, or a Scotchbrite pad.



### **CAUTION**

*DO NOT use any alkaline (base) polishes.*





---

## **Turntable Attachments**

The bolts attaching the turntable assembly to the rotation bearing are 5/8-11 NCX 2" long-grade 8. They are special bolts with self-locking threads. Should replacement be necessary, they must be replaced with an equivalent bolt (contact Sutphen Towers, Inc. for detailed requirements).

There are 24 bolts on the turntable. These bolts have a SAE hardened washer and are factory-installed to torque of 150-200 ft. lbs. This torque should be checked every three (3) months. Any indication of loosening or bolt failure should be reported to Sutphen Towers, Inc. for evaluation and disposition.

There are 30 bolts attaching the rotation bearing to the support structure. They are 5/8-11 NCX 4 1/2" long-grade 8 with an SAE hardened washer under the head and a grade "C" lock nut. These assemblies are factory-installed to a torque of 150-200 ft. lbs. and should be checked every three (3) months. The heads of these bolts are accessible through two 3" diameter holes in the turntable plate.

The turntable must be rotated for access to check all bolts. Any indication of loosening or bolt failure should be reported to Sutphen Towers, Inc. for evaluation and disposition.



### **CAUTION**

*The person operating the turntable for bolt alignment must make sure all persons and tools are free and clear before rotating turntable.*

## **Attachment of Support Structure to Truck Frame**

Your vehicle was assembled with the method of attaching the aerial support structure to the chassis below.

▼ **Maintenance Manual**

Method: Huck Fasteners

There are twelve (12) fasteners on each side of the aerial support structure, six (6) front and six (6) rear each side. These twenty-four (24) assemblies are 16mm Huck Bobtail Lockbolts. These fasteners are factory installed with specialized equipment, and do not require re-torquing. They should be inspected every three months. Any indication of loosening or bolt failure should be reported to Sutphen Towers, Inc. For evaluation and disposition

**NOTE: Sutphen recommends that once a week the ladder is raised to full elevation, full extension, and rotated 360 degrees in both directions.**

### **Aerial Tower & Ice Build Up**

A well lubed boom, UHMW and other non-metal surfaces will also have low stiction regarding ice. But if the conditions are optimal for ice formation and/or another aerial is being used upwind from our boom, ice will build up unless steps are taken to minimize the buildup. Including moving the boom intermittently. You still need to observe cord reel during extend or retract operations in the unlikely event ice has accumulated on electric cord.

1. Raise/lower & rotate the boom to help break any built-up ice as much as possible; do not retract or extend.
2. Get up on the climbing ladder and/or rotate the boom, lower it off to one side if possible and check the cord reel; you'll want to remove any pieces of ice that could cause damage.
3. Retract the boom slowly while making sure everything is moving freely without any ice and/or other debris getting bound up between the sections, cables, climbing ladders, or cord reel.



4. Refrain from using tools to break the ice off-but if just needing to remove random build up make sure it's a plastic type of tool and use as little force as possible. No metal hammers or prybars.
5. Using direct flame is also a bad idea: too much plastic, cable loom/sheathing, and UHMW blocks that end up getting burnt and would then need replaced. It would be possible to use portable torpedo Oil/Kerosene heaters, extreme caution is advised, but wind could render this option useless.



## **CAUTION**

*Retracting with ice built up can result in a full cord reel replacement, and some lacings & crossmembers. If it must be done, the hydraulics will ultimately win the battle.*

**Maintenance Manual**

## AERIAL TOWER LUBRICATION AND MAINTENANCE SCHEDULE

LUBRICATION POINTS	LUBRICANT	INTERVAL	MONTHLY	ANNUALLY
STABILIZERS	Pro-One EP-2 Grease	AS NEEDED OR		X
MAIN LIFT CYLINDER	Pro-One EP-2 Grease	25 OPERATING HOURS OR		X
PIVOT SHAFT BEARING	Pro-One EP-2 Grease	25 OPERATING HOURS OR		X
TURNTABLE BEARING	Pro-One EP-2 Grease	FIRST 3 MO. THEN		X
DRIVE GEAR	Pro-One EP-2 Grease	AS NEEDED OR		X
ROTATION GEAR	140 wt. Gear Oil	AS NEEDED OR		X
EXTENSION-RETRACTION CYLINDER(S)	ProOne EP-2 Grease (SL75 only)	EVERY 6 MONTHS OR		X
OUTRIGGER PINS	Pro-One EP-2 Grease		X	X
SHEAVES	Pro-One EP-2 Grease	25 OPERATING HOURS OR		X
CABLES	Vitalife 400 OR Chain Mate	25 OPERATING HOURS OR		X
SLIDE BLOCKS	Prizm or Pro-One EP2 Grease	25 OPERATING HOURS OR	X	X
WATERWAY AND SEALS	Shell V1002 Lithium Grease		X	
WATERWAY NOZZLE	Pro-One EP-2 Grease			X
PLATFORM POWER CABLE	Dow #4 Silicone Grease	AS NEEDED OR		X
LEVELING SYSTEM	DexMerc			X
HYDRAULIC OIL	DexMerc	ADD AS NEEDED		2 YRS.
HYDRAULIC OIL FILTER(S)	None Required	CHANGE AT 50 OPERATING HOURS or FIRST 3 MONTHS (whichever comes first) THEN		X
PLATFORM CYLINDER PIVOT ROD END	Pro-One EP-2 Grease			X
LEVELING SYSTEM	Pro-One EP-2 Grease			X



## TORQUE SPECIFICATIONS

ITEM	SIZE	TORQUE	INTERVAL	MONTHLY	ANNUALLY
#1. TURNABLE TO ROTATION BEARING	5/8-11	150-200 FT. LBS.	FIRST 3 MONTHS THEN		X
#2. ROTATION BEARING TO SUPPORT STRUCTURE	5/8-11	150-200 FT. LBS.	FIRST 3 MONTHS THEN		X
#3. LOWER ASSEMBLY SIDE PLATE TO TRUCK FRAME	16MM	VISUAL INSPECTION ONLY FOR HUCK FASTENERS	FIRST 3 MONTHS THEN		X
#4. ROTATION GEAR MOUNTING (WINSMITH BOLTS)	½-13	75-100 FT. LBS.	FIRST 3 MONTHS THEN		X
#5. YOKE TO LADDER BOLTS (SP70 ONLY)	5/16-18	20-25 FT. LBS	FIRST 3 MONTHS THEN		X
#6. PIVOT SHAFT BEARING BOLTS	7/16-17	40-55 FT. LBS.	FIRST 3 MONTHS THEN		X
#7. WATERWAY MOUNT BOLTS	3/8-16	45 FT. LBS.	FIRST 3 MONTHS THEN		X
#8. CYLINDER MOUNT BOLTS	3/8-16	25-35 FT. LBS.	FIRST 3 MONTHS THEN		X
#9. CABLE ADJUSTMENTS		-----	FIRST 3 MONTHS THEN	X	
#10. SHEAVE BEAM BOLTS	5/16-18 3/8-16	20-25 FT. LBS. 30-40 FT. LBS.	FIRST 3 MONTHS THEN		X
#11. SLIDE BLOCK BOLTS	5/16-18	24 IN. LBS.	FIRST 3 MONTHS THEN		X
#12. PIVOT SHAFT END CAPS	7/16-14	35-40 FT. LBS.	FIRST 3 MONTHS THEN		X
#13. LIFT CYLINDER PIN RETAINERS	3/8-16	45 FT. LBS.	FIRST 3 MONTHS THEN		X
#14. YOKE TO LADDER	5/16-18	20-25 FT. LBS.	FIRST 3 MONTHS THEN		X
#15. EXTEND/RETRACT CYLINDER ROD BOLT	SA75 (NA) SP70 (NA) SL75 3/8-16	25-35 FT. LBS.	FIRST 3 MONTHS THEN		X
#16. PLATFORM TO YOKE PIVOT	½-13	75-85 FT. LBS.	FIRST 3 MONTHS THEN		X
#17. LEVELING CYLINDER ANCHOR	3/8-16	45 FT. LBS.	FIRST 3 MONTHS THEN		X
#18. PLATFORM PIVOT BLOCK	3/8-16	45 FT. LBS.	FIRST 3 MONTHS THEN		X

▼ **Maintenance Manual**

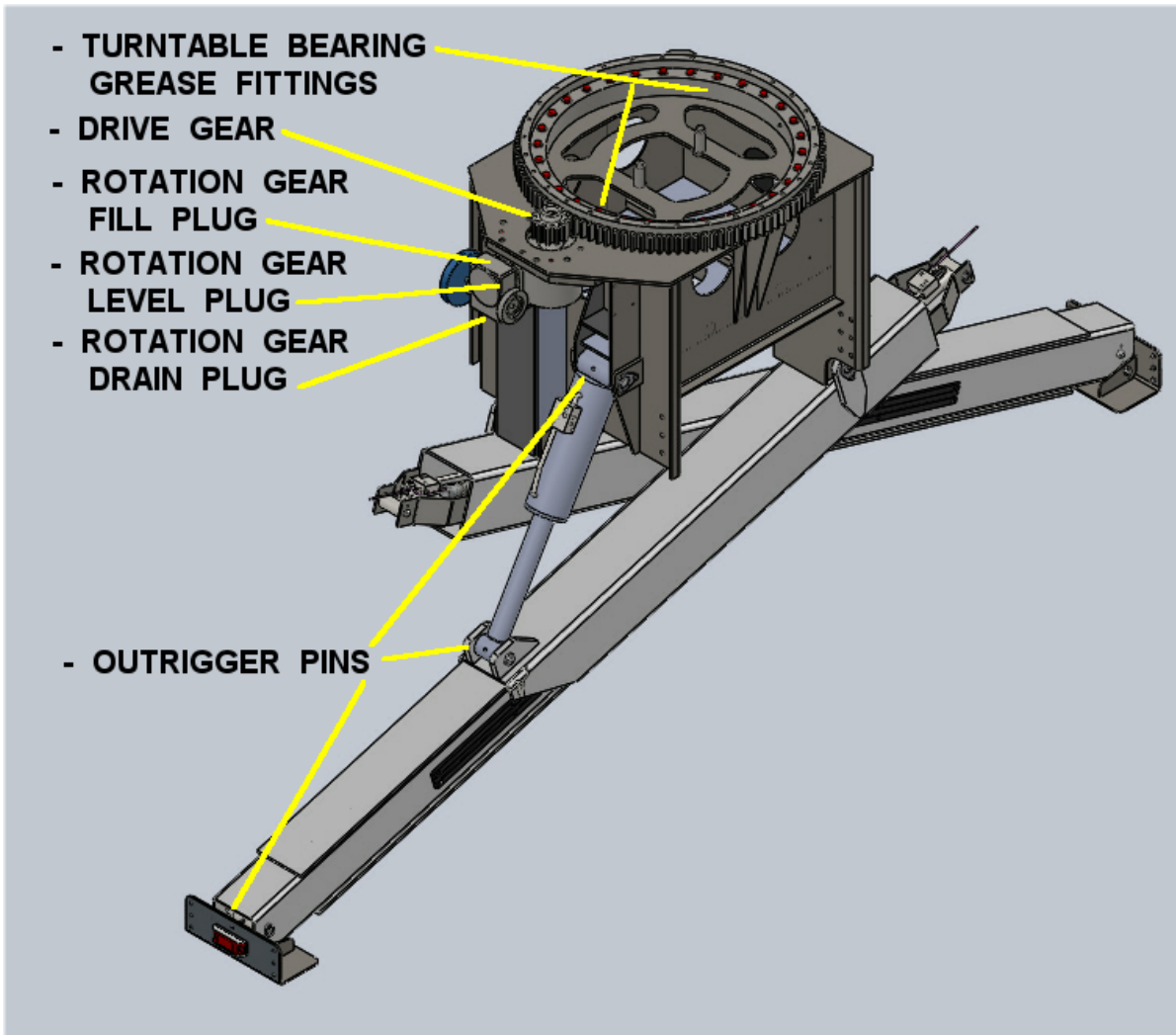
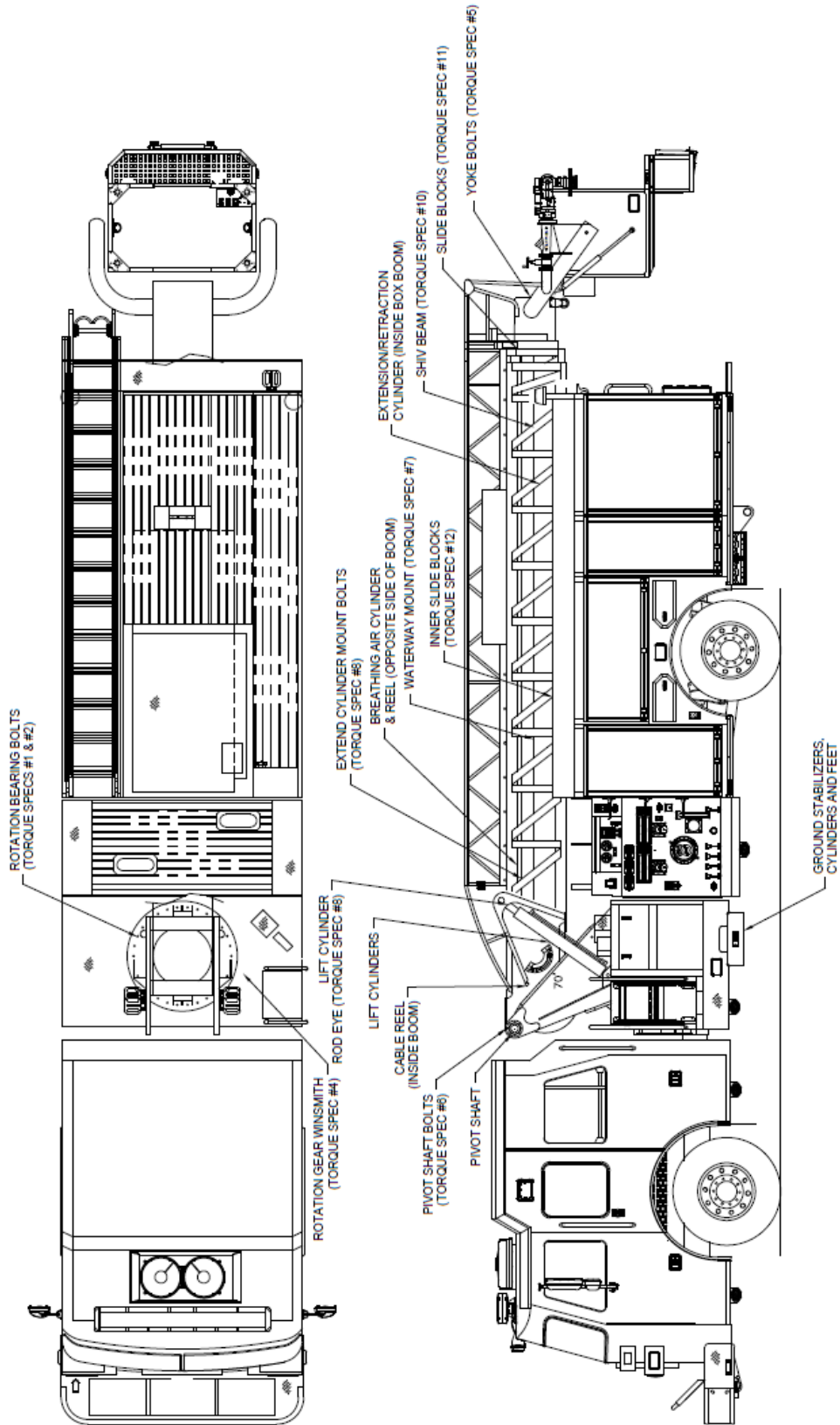

Figure 15



# LUBRICATION AND TORQUE POINTS SP70



**Maintenance Manual**

**LUBRICATION AND TORQUE POINTS**

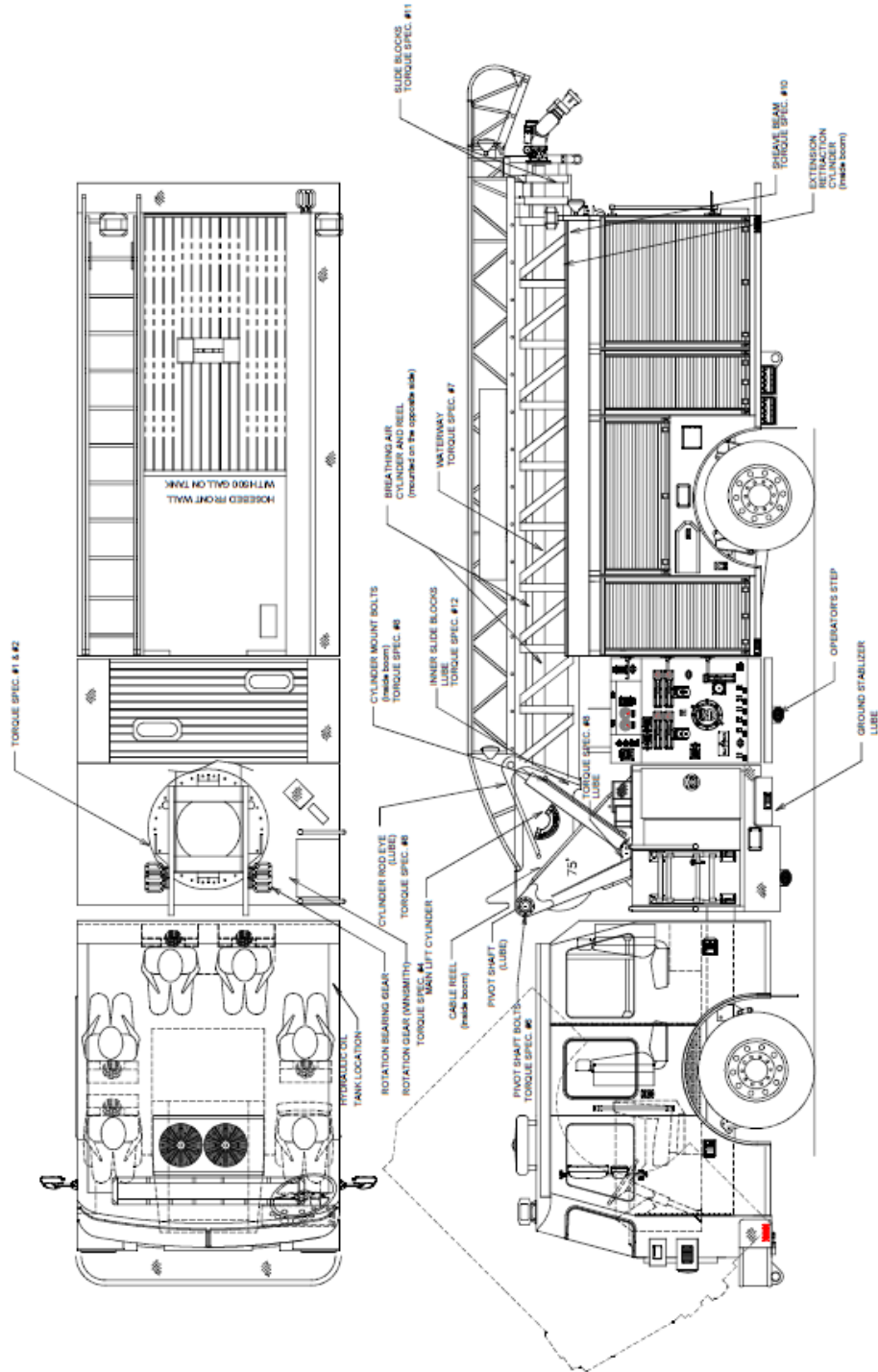

JRG 2001NOV21 DWG. NO. 11 B00123aRevG  
 REV. 03/2014/02/07/04





# LUBRICATION AND TORQUE POINTS

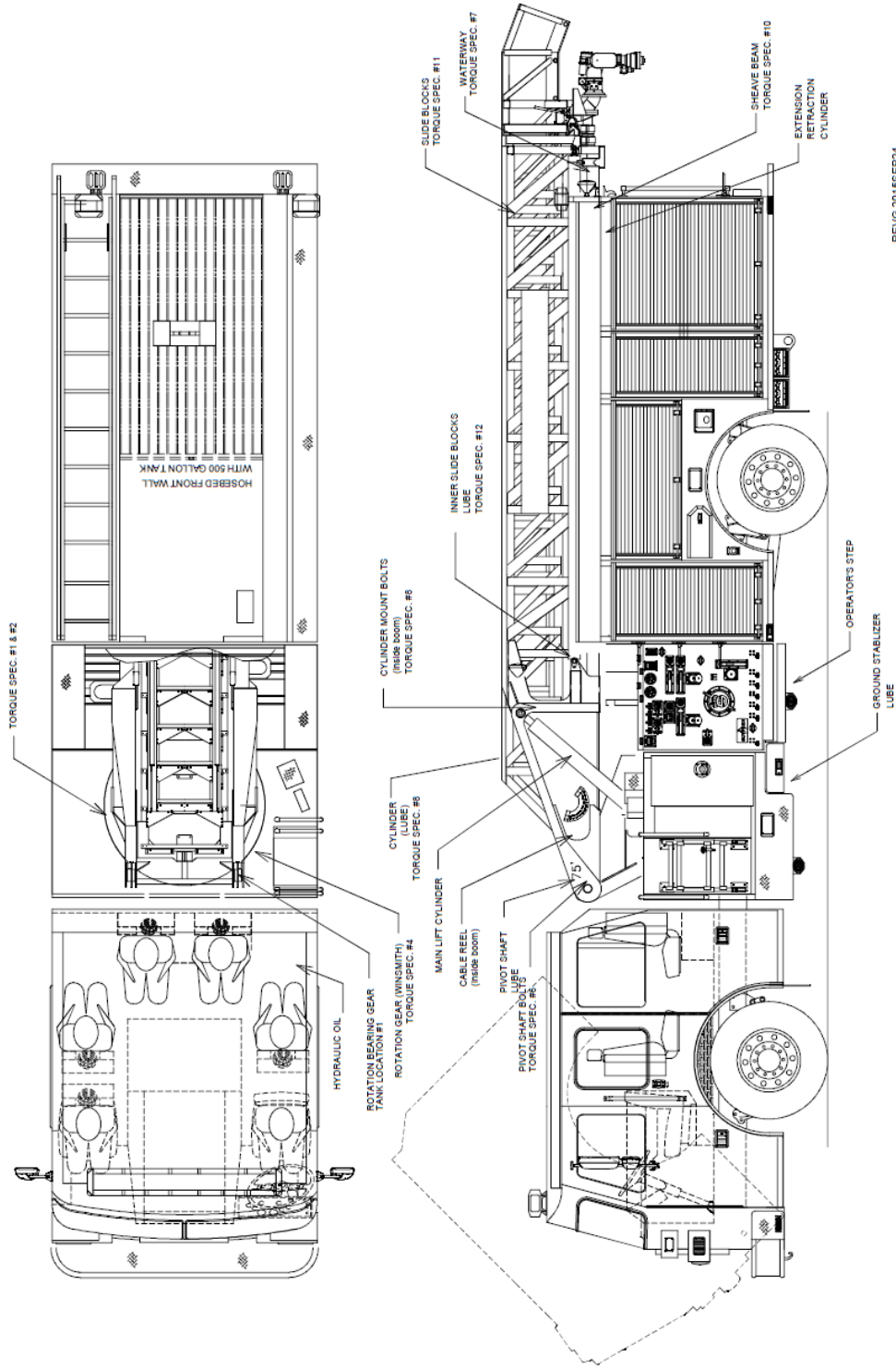

REV G 2015 SEP 24  
JRG 2012 JUL 16 DWG. NO. 11B0123 rev G

**WALK-AROUND CHECKS  
FOR MOBILE FIRE APPARATUS**

Fire Department Name:	Date:	Special Instructions:
Truck Model:	HS #:	
Truck Number:	Station #:	
Start Mileage:	Start Engine Hours:	
End Mileage:	End Engine Hours:	

**Legend:** Rec Min. = Recommended Minimum Interval for Inspection

OPERATIONS	Daily	Weekly	Monthly	6 Months	Annual
<b>Engine – Tilt Cab – Make sure safety prop is engaged and there are no obstructions on the bumper or in the cab.</b>					
1. Check engine oil and transmission level. Check for leaks (see Manual).	Rec Min.				
2. Check engine coolant level – sight glass. Check for leaks.	Rec Min.				
3. Check for integrity of frame and suspension, as well as motor assembly and mount. Check for loose bolts.			Rec Min.		
4. Check power steering fluid level and look for leaks in the fitting or hoses. Transynd	Rec Min.				
5. Check belts for tightness and wear.	Rec Min.				
6. Check steering shafts.			Rec Min.		
7. Check for exhaust leaks. Check heat shields are in place.			Rec Min.		
<b>Outside</b>					
1. Check for fluid leaks under vehicle.	Rec Min.				
2. Check steering shafts and linkages.			Rec Min.		
3. Check wheels and lug nuts for tightness.			Rec Min.		
4. Check tire condition. – Tread Depth. (wear/damage)	Rec Min.				
5. Check tire air pressure.	Rec Min.				
6. Verify all warning label & placards are in place (see Manual).		Rec Min.			
7. Check driveline U-joints and slip joints. Lubricate if necessary. Check for tightness on all universal bolts. Visual check.			Rec Min.		
<b>Cab – lower cab</b>					
1. Check seats and seat belts (damage/warning system) and ensure working properly.	Rec Min.				
2. Start engine, check all gauges, switches, & controls.	Rec Min.				
3. Check windshield wipers & washer fluid level check	Rec Min.				
4. Check rear view mirrors adjustment and operation. R & L	Rec Min.				
5. Check horn, air horn, siren and backup alarm.	Rec Min.				
6. Check all gauges for correct reading after start. Fuel Level Check.	Rec Min.				
7. Check cab glass and mirrors.	Rec Min.				
<b>Body</b>					
1. Check steps and running boards. (damage/loose hardware)	Rec Min.				
2. Check body condition. (doors/latching)	Rec Min.				
3. Check grab handles. (Hardware tight secure)	Rec Min.				
<b>Electric</b>					
1. Check battery voltage and charging system voltage, 13 +VDC.	Rec Min.				
2. Check all lights (ICC and warning); headlights.	Rec Min.				

OPERATIONS	Daily	Weekly	Monthly	6 Months	Annual
3. Check operation of battery charger and receptacle.	Rec Min.				
<b>Brakes</b>					
1. Check the air system for proper air pressure. (See tech manual)	Rec Min.				
2. Check parking brake operation.	Rec Min.				
3. Check air compressor operations. Cut in _____ Cut out _____	Rec Min.				
4. Check hoses or lines for rubbing.			Rec Min.		
5. Drain wet air tank to make sure air dryer is working properly			Rec Min.		
<b>Pump</b>					
1. Operate pump, check pump panel engine gauges.	Rec Min.				
2. Check pump for pressure operation.	Rec Min.				
3. Check discharge relief or pressure governor operation.	Rec Min.				
4. Check all pump drain valves.		Rec Min.			
5. Check all discharge and intake valve operation.		Rec Min.			
6. Check pump and tank for water leaks.		Rec Min.			
7. Check all valve bleeder/drain operation.		Rec Min.			
8. Check primer pump operation.			Rec Min.		
9. Check system vacuum hold.			Rec Min.		
10. Check water tank level indicator.	Rec Min.				
11. Check primer oil level (if applicable).		Rec Min.			
12. Check transfer valve operation (if equipped).			Rec Min.		
13. Check booster reel operation (if equipped).		Rec Min.			
14. Check all pump pressure gauge operation.	Rec Min.				
15. Check all cooler valves.			Rec Min.		
16. Check for oil leaks in pump area.	Rec Min.				
17. Check oil level of pump transmission.			Rec Min.		
18. Check hour meter operation (If equipped)	Rec Min.				
19. Check operation of valve linkage.	Rec Min.				
20. Check ball valves for leaks.		Rec Min.			
21. Check drain valves.		Rec Min.			
<b>Generator</b>					
1. Operations – Hydraulic, Gas, or Diesel	Rec Min.				
2. Fluid levels	Rec Min.				
3. Breakers, Receptacles, lighting for operations		Rec Min.			
4. Voltage Reading, 240V AC		Rec Min.			
Amp Reading		Rec Min.			
HTZ Reading, 60HTZ		Rec Min.			
<b>Aerial Device</b>					
1. Visually inspect aerial structure, slide blocks, cables, sheaves, lacing bolts/ huck bolts and any moving assembly.		Rec Min.			
a. Sheaves – lubed and look for signs of wear		Rec Min.			
b. Slide blocks – all in place (no visible signs of excess wear or damage)		Rec Min.			
2. Check aerial operation – all controls, bucket & pedestal.		Rec Min.			
3. Elevation cylinder, check for leaks & wiper seal (check RAM for pits and/or damage).		Rec Min.			
4. Extension cylinder, check for leaks & wiper seal (check RAM for pits and/or damage).		Rec Min.			
5. Lines & hoses – check for leaks and cuts.		Rec Min.			
6. Check aerial hour meter operation and record hours.		Rec Min.			

OPERATIONS	Daily	Weekly	Monthly	6 Months	Annual
7. Check breathing air system.		Rec Min.			
8. Cable adjustment not too tight and not to lose check all cables and sections. Review tolerance. (See directions in manual)			Rec Min.		
9. Observe operation of cable track system check for debris and/or damage.		Rec Min.			
<b>Waterway</b>					
1. Check waterway system operation, alignment, and check for damage.		Rec Min.			
<b>Hydraulic System</b>					
1. Check aerial hydraulic fluid level. Dex/Merc		Rec Min.			
2. Check high pressure filter under load to ensure it is still in the green and not in bypass as well as return the filter.		Rec Min.			
3. Turn on auxiliary hydraulic power pump – check operation.		Rec Min.			
<b>Turntable</b>					
1. Operate aerial hydraulics + PTO operation (check for leaks or damaged hoses). Verify Indicator Light is functional.		Rec Min.			
2. Rotation		Rec Min.			
3. Rotation hydraulic swivel, check for leaks		Rec Min.			
4. Lines and hoses (for leaks & cuts)		Rec Min.			
5. Pivot pin bolts tight on boom to turn table pivot bearing plate (Heal Pin).			Rec Min.		
6. Check manual overrides.			Rec Min.		
7. Check cradle alignment light and mounting.		Rec Min.			
8. Check pinion and rotation bearing (Winsmith/rotation drives).			Rec Min.		
<b>Turntable Components or Hydraulic Compartment</b>					
1. Safety signs			Rec Min.		
2. Communication system or intercom		Rec Min.			
3. Interlock systems - operational		Rec Min.			
4. High-speed button operational		Rec Min.			
<b>Platform/Bucket</b>					
1. Leveling cylinders, leaks and wiper seal		Rec Min.			
2. Lines and hoses, cuts & leaks		Rec Min.			
3. Check operation of high speed.		Rec Min.			
4. Check operation of intercom system		Rec Min.			
<b>Platform/Bucket (continued)</b>					
5. Check breathing air system in platform - check for leaks and hose condition		Rec Min.			
6. Inspect monitors/turret for operation		Rec Min.			
7. Verify cab avoidance system is operational		Rec Min.			
8. Verify bucket leveling system is operational		Rec Min.			
9. Verify all accessories are secure in the platform		Rec Min.			
<b>Structural Fasteners - See Manual for Reference</b>					
1. Turntable mounting bolts - visual check for tightness				Rec Min.	
2. Chassis Suspension system bolts – visual check for tightness				Rec Min.	
<b>Stabilizers</b>					
1. Check aerial outrigger operation		Rec Min.			
2. Check aerial jack & rotation interlocks for operation		Rec Min.			
3. Indicator lights working		Rec Min.			
4. Jack pads in proper location & serviceable		Rec Min.			
5. Mounting bolts – visual check for tightness		Rec Min.			
6. Verify safety lock pins operation in aerial jacks and in location		Rec Min.			

<b>OPERATIONS</b>	<b>Daily</b>	<b>Weekly</b>	<b>Monthly</b>	<b>6 Months</b>	<b>Annual</b>
7. Cylinders – check for leaks & wiper seals		Rec Min.			
8. Control valve – smooth operation		Rec Min.			
9. Lines & hoses – check for leaks and cuts		Rec Min.			
10. Diverter valve – check for leaks		Rec Min.			
<b>Lubrication</b>					
<b>Grease Parts and Assemble as Required per the Trucks Maintenance Manual:</b>					
1. Sheaves - Min. Wkly or more if hours of operation dictate		Rec Min.			
2. Cables, wipe down with damp cloth, Lubricate with Vitalife 400 or Chain Mate		Rec Min.			
3. Prizm or ProOne Grease on boom section, Review and add where needed per manual		Rec Min.			
4. Rotation gear and bearing				Rec Min.	
5. Rotation gear reduction box				Rec Min.	
6. Extension cylinder pins, grease pivot				Rec Min.	
7. Stabilizer extension cylinder pins				Rec Min.	
8. Aerial waterway pipe sections, lubricate with Shell V1002 Lithium Grease		Rec Min.			
9. Grease turret guns		Rec Min.			
<b>Indicators</b>					
1. Validate rung alignment operation; pedestal and bucket		Rec Min.			
2. PTO engaged in cab		Rec Min.			
3. Aerial alignment light for cradle bedding		Rec Min.			
4. Elevation/inclometer in bucket		Rec Min.			
5. Inclometer in turntable area for truck level.		Rec Min.			
<b>Comments:</b>					



**FAMILY OWNED  
SINCE 1890**

# Draining & Winterizing Trucks

It is critical, especially during the cold months, to exercise caution when it comes to leaving trucks outside, transporting trucks, or accepting trucks into our possession. Anyone who gets behind the wheel of a truck is responsible for ensuring the truck is properly drained and stored.

## **Sutphen Guidelines for Draining and Winterizing Trucks**

1. Communicate to all that water and foam tanks must be emptied prior to dropping any truck off to Sutphen for service.
2. Drain all trucks left outside completely, including water tanks, pumps, gauges and valves.
3. Ensure all valves (outboard and inline) are open 50% to drain trapped water.
  - Use caution if valve appears to be frozen in place; do not force a valve open or closed. Trucks may need warmed-up prior to operating frozen valves.
4. Run "RV antifreeze" through the foam pump and systems immediately after foam testing (approx. 3 gal.) from October through April.
5. Any truck being "Road Tested" needs to have all valves and drains open 50% to drain any trapped water. After road testing, the tank fill needs to be opened 100% to allow draining back into the pump. Ensure tank fill is turned back to 50% open after tank has fully drained back into the pump.

Please ensure everyone is fully aware of the expectations and follows the same guidelines. Thank you for your cooperation and dedication to avoiding costly repairs.







## **Chapter 3 Warranty**

	<u><i>Page</i></u>
Aerial Platform or Aerial Ladder Structural and Corrosion Warranty Thirty (30) Years.....	3-1
Aerial Platform and Aerial Ladder Mechanical Warranty Two (2) Years.....	3-2



## AERIAL PLATFORM OR AERIAL LADDER STRUCTURAL & CORROSION WARRANTY THIRTY (30) YEARS

SUTPHEN CORPORATION (Sutphen) warrants the original user/purchaser that a new aerial platform or aerial ladder is, and will remain, free of corrosion perforation and structural defects, provided the aerial platform is used in a normal and reasonable manner. An aerial platform or aerial ladder is defined as the mechanically operated telescopic boom constructed of high-strength structural aluminum mounted on the fire truck. Excluded are all hardware, mechanical or electrical items, bucket, yoke and all normal wear items. The truck must be third party tested yearly. The Sutphen hourly maintenance schedule must be sent in to Sutphen for documentation that this work was performed per hourly schedule. This Structural Warranty shall supplement the Standard Vehicle Warranty.

Sutphen's obligation under this limited warranty is subject to the conditions precedent (1) that the claimed failure shall have first appeared during the warranty period; (2) that the original purchaser shall have notified Sutphen in writing of the claimed failure within thirty (30) days after the claimed failure shall have first appeared, and (3) that, unless Sutphen directs otherwise, the claimed failed item or items shall have been returned to Sutphen, or to Sutphen designee, promptly after the notification, with transportation charges prepaid. Sutphen reserves the right to thoroughly examine the vehicle or parts thereof, prior to conducting or approving any repair or replacement, to determine whether the claimed failure is covered by this warranty. Sutphen's obligation under this warranty is strictly limited to repair or replacement as the company may elect.

This limited warranty coverage shall be valid for a period of thirty (30) years from the delivery date to the original user/purchaser. Further, this warranty shall be void if the vehicle is involved in an accident, shows signs of abuse, or evidence of being operated in any improper manner.

This limited warranty covers only repair or replacement of any part of a Sutphen vehicle in which a defect in materials or workmanship appears within the limited warranty period. Examples of items not covered include, but are not limited to:

- A. ---Major components or trade accessories such as purchased chassis, engines, signaling devices, batteries, generators, tires, or transmissions that have a separate warranty by the original manufacturer, or to equipment used in firefighting.
- B. ---Unauthorized alteration or modification to the vehicle, including the body, chassis or components, after completion of the vehicle assembly by Sutphen and any problems that occur as a result of such alterations or modifications.
- C. ---Damage caused by collision, fire, theft, freezing, vandalism, riot, explosion, acts of God, war or objects striking the vehicle or any damage covered by owner insurance.
- D. ---Damage caused by misuse or improper operation of the vehicle such as driving over curbs, overloading, racing or off-road use.
- E. ---Damage caused by failure to follow the requirements of the maintenance schedule, failure to maintain proper fluid and lubricant levels and failure to follow operating instructions.
- F. ---Towing charges and storage expenses.
- G. ---Incidental expenses such as loss of vehicle use, inconvenience, loss of time, vehicle rental, lodging or travel costs, vacation pay, etc.
- H. ---Hydraulic pressures are not set to the correct PSI.
- I. ---Damage caused from exposure to road de-icing compounds or use in an acidic environment.
- J. ---Hydraulic failures caused by incorrect or contaminated oil.
- K. ---Hydraulic cylinder seal after one (1) year of service.

If proper maintenance has not been performed and documented on Sutphen Aerial Platform or Aerial Ladder Inspection forms and the forms sent to Sutphen at the time of check, all coverage is void.

This warranty terminates upon transfer of possession or ownership of the vehicle from the original purchaser.

THIS WARRANTY IS PROVIDED IN EXCLUSION OF ANY AND ALL OTHER REPRESENTATIONS, EITHER EXPRESSED OR IMPLIED, INCLUDING BUT NOT LIMITED TO THE WARRANTIES OF MERCHANTABILITY, FITNESS, AND SUITABILITY FOR BUYER'S INTENDED USE. NO PERSON IS AUTHORIZED TO MAKE ANY REPRESENTATIONS OR WARRANTIES ON BEHALF OF SUTPHEN CORPORATION OTHER THAN SET FORTH HEREIN. ANY MODIFICATION TO THIS WARRANTY MUST BE IN WRITING AND APPROVED BY THE PRESIDENT OF SUTPHEN CORPORATION. THE PROVISIONS OF THIS LIMITED WARRANTY SHALL CONSTITUTE THE SOLE AND EXCLUSIVE REMEDIES OF A SUTPHEN VEHICLE PURCHASER.

For more information contact:  
Sutphen Corporation / Warranty Admin.  
PO Box 1845 • Springfield, OH 45501  
Phone (937) 969-8851 • Toll Free (866) 287-5549



## AERIAL PLATFORM AND AERIAL LADDER MECHANICAL WARRANTY TWO (2) YEARS

SUTPHEN CORPORATION (Sutphen) warrants the original user/purchaser that the mechanical components of a new aerial platform or aerial ladder is, and will remain, free of corrosion perforation, structural defects, or failure provided that the components are used in a normal and reasonable manner. Mechanical components are defined as the hardware and mechanical items used on an aerial device. This Mechanical Warranty shall supplement the Standard Vehicle Warranty.

Sutphen's obligation under this limited warranty is subject to the conditions precedent (1) that the claimed failure shall have first appeared during the warranty period; (2) that the original purchaser shall have notified Sutphen in writing of the claimed failure within thirty (30) days after the claimed failure shall have first appeared, and (3) that, unless Sutphen directs otherwise, the claimed failed item or items shall have been returned to Sutphen, or to Sutphen designee, promptly after the notification, with transportation charges prepaid. Sutphen reserves the right to thoroughly examine the vehicle or parts thereof, prior to conducting or approving any repair or replacement, to determine whether the claimed failure is covered by this warranty. Sutphen's obligation under this warranty is strictly limited to repair or replacement as the company may elect.

This limited warranty coverage shall be valid for a period of two (2) years from the delivery date to the original user/purchaser. Further, this warranty shall be void if the vehicle is involved in an accident, shows signs of abuse, or evidence of being operated in an improper manner.

This limited warranty covers only repair or replacement of any part of a Sutphen vehicle in which a defect in materials or workmanship appears within the limited warranty period. Examples of items not covered include, but are not limited to:

- A. ---Major components or trade accessories that have a separate warranty by the original manufacturer, or equipment used in firefighting.
- B. ---Unauthorized alteration or modification to the vehicle, including the aerial, body, chassis or components, after completion of the vehicle assembly by Sutphen and any problems that occur as a result of such alterations or modifications.
- C. ---Damage caused by collision, fire, theft, freezing, vandalism, riot, explosion, acts of God, war or objects striking the vehicle or any damage covered by owner insurance.
- D. ---Damage caused by misuse or improper operation of the vehicle such as driving over curbs, overloading, racing or off-road use.
- E. ---Damage caused by failure to follow the requirements of the maintenance schedule, failure to maintain proper fluid and lubricant levels and failure to follow operating instructions.
- F. ---Normal maintenance items such as lubrication, cables, shives, pivot bearings, pivot shafts, etc.
- G. ---Towing charges and storage expenses.
- H. ---Incidental expenses such as loss of vehicle use, inconvenience, loss of time, vehicle rental, lodging or travel costs, vacation pay, etc.
- I. ---Damage to discharge and compound gauges from freezing.
- J. ---Leaking seals on discharge and suction valves.
- K. ---Damage caused from exposure to road de-icing compounds or use in an acidic environment.
- L. ---Hydraulic failures caused by incorrect or contaminated oil.
- M. ---Hydraulic pressure caused by incorrect PSI settings.
- N. ---Hydraulic cylinder seal after one (1) year service.
- O. ---Electric reels, air reels, electric controls and components.

If proper maintenance has not been performed and documented on Sutphen Aerial Inspection forms and sent to Sutphen at time of check, all coverage is void.

This warranty terminates upon transfer of possession or ownership of the vehicle from the original purchaser.

THIS WARRANTY IS PROVIDED IN EXCLUSION OF ANY AND ALL OTHER REPRESENTATIONS, EITHER EXPRESSED OR IMPLIED, INCLUDING BUT NOT LIMITED TO THE WARRANTIES OF MERCHANTABILITY, FITNESS, AND SUITABILITY FOR BUYER'S INTENDED USE. NO PERSON IS AUTHORIZED TO MAKE ANY REPRESENTATIONS OR WARRANTIES ON BEHALF OF SUTPHEN CORPORATION OTHER THAN SET FORTH HEREIN. ANY MODIFICATION TO THIS WARRANTY MUST BE IN WRITING AND APPROVED BY THE PRESIDENT OF SUTPHEN CORPORATION. THE PROVISIONS OF THIS LIMITED WARRANTY SHALL CONSTITUTE THE SOLE AND EXCLUSIVE REMEDIES OF A SUTPHEN VEHICLE PURCHASER.

For more information contact:  
Sutphen Corporation / Warranty Admin.  
PO Box 1845 • Springfield, OH 45501  
Phone (937) 969-8851 • Toll Free (866) 287-5549



