

M6 INDIVIDUAL TAIL LIGHT'S

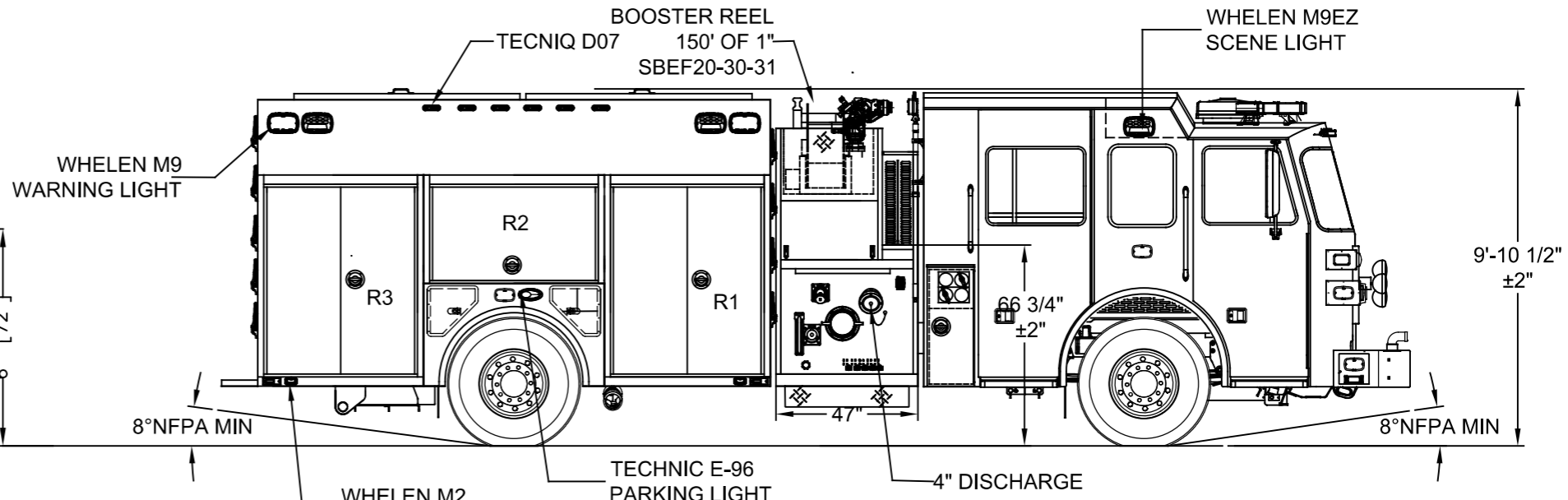
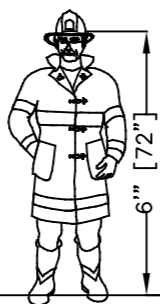

Left Side Compartmentation				
Compt	Doors	Opening Dimensions	Inside Dimensions	Volume
WxHxD				
L1	HINGE	48x60	55x66x24.25	46.3 CU FT
L2	HINGE	53x26	60x35x24.25	25.3 CU FT
L3	HINGE	48x60	55x66x24.25	46.3 CU FT

Right Side Compartmentation				
Compt	Doors	Opening Dimensions	Inside Dimensions	Volume
R1	HINGE	48x60	55x66x24.25	46.3 CU FT
R2	HINGE	53x26	60x35x24.25	25.3 CU FT
R3	HINGE	48x56	55x66x24.25	46.3 CU FT

Rear Compartmentation				
Compt	Doors	Opening Dimensions	Inside Dimensions	Volume
A1	Roll Up	44x18	48x28x22.25	17.3 CU FT

Coffin Compartmentation				
Compt	Doors	Opening Dimensions	Inside Dimensions	Volume
LxHxW				
LH	Hatch	(2) 75x22	170x25x26	64 CU FT
RH	Hatch	(2) 75x22	170x25x26	64 CU FT

LADDER CHUTE
24' 2 SEC
14' ROOF
10' FOLDING
SCBA STORAGE
LFF: TRIPLE SCBA
LRF: FUEL FILL AND SCBA
RRF: TRIPLE SCBA
RRF: OIL DRY HOPPER

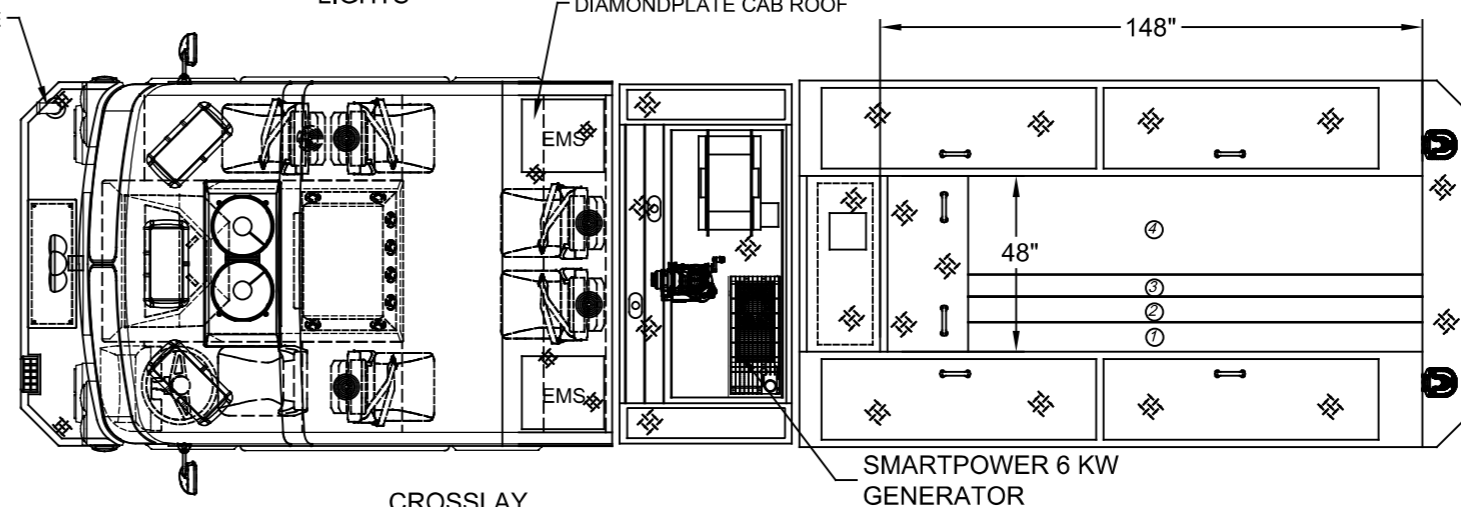

Hose Load
1: 200ft of 2 1/2"
2: 350ft of 1 3/4" Pre-Connect
3: 200ft of 3" Pre-Connect
4: 1200ft of 5"

WATEROUS CSU-2000 GPM SS 500 GAL WATER TANK

Total Volume	353.2 CU Ft
--------------	-------------

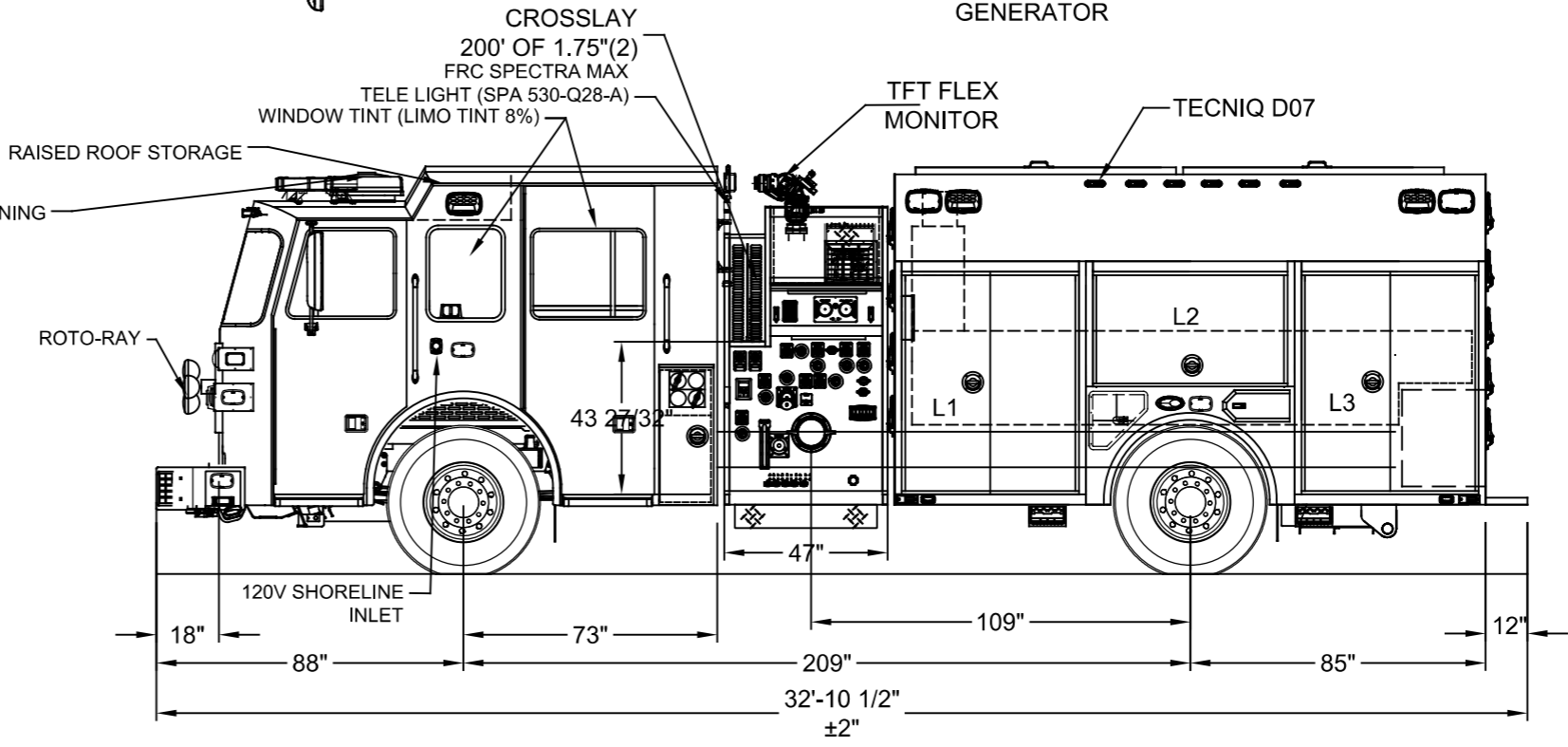
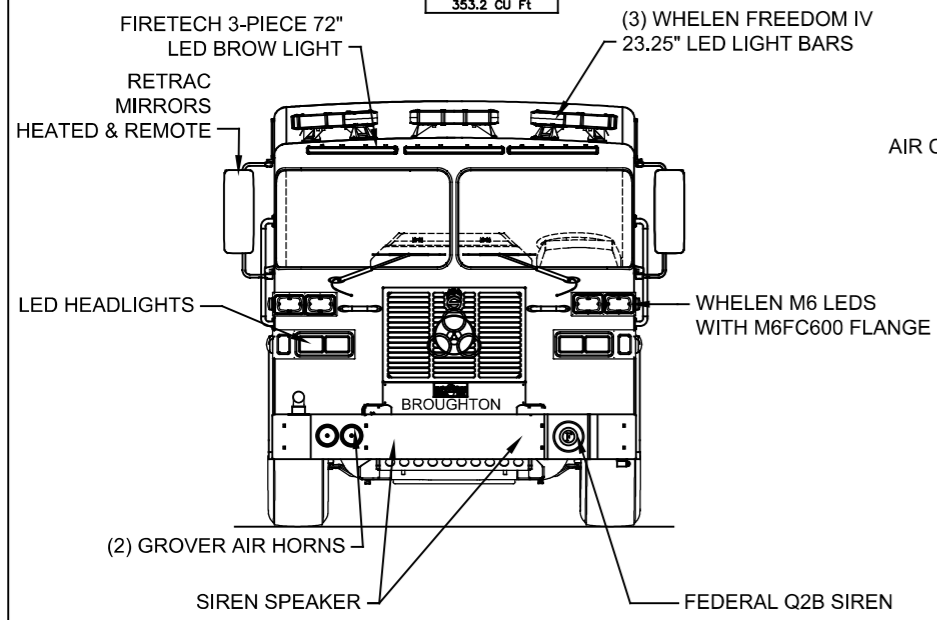

DIMENSIONS SHOWN ON THIS DRAWING ARE APPROXIMATE AND ARE SUBJECT TO MINOR DEVIATIONS DURING CONSTRUCTION.
IN THE EVENT OF A DISCREPANCY BETWEEN THE SUTPHEN SPECIFICATIONS AND DRAWING, THE SUTPHEN SPECIFICATIONS SHALL PREVAIL.
DRAWING IS FOR REFERENCE ONLY. SOME ITEMS PROPOSED MAY NOT BE SHOWN OR NOTED.

CUSTOMER APPROVAL

NAME: _____
TITLE: _____
DATE: _____

REV.	DESCRIPTION	BY	DATE
REV P	TECNIQ D07 LIGHTS ON SIDE OF COFFINS WITH RGB CONTROLLER	RR	7/11/24
REV H	COMPARTMENTS, SCENE LIGHTS, MIRRORS, BLIND SPOT MIRROR, MONITOR	RR	06/30/23
REV B	RAISED ROOF, TELE LIGHT BUMPER TROUGH	RR	05/01/23
REV A	CHANGES FROM PRE-CON	RR	12/28/22

DRAWN BY:	RAGHU
DATE:	6-2-22
MFG. FACILITY:	SUTPHEN EAST LAKE ARIEL, PA

SUTPHEN
BROUGHTON VOLUNTEER FIRE DEPARTMENT
PITTSBURGH, PA
CUSTOM PUMPER - PS-09
HS-7669