

REAR CAMERA
RECESSED WITH
CHROME FLANGE

Hose Load
1:300FT OF 2-1/2" PRE-CONNECTED
2:1200FT OF 5"

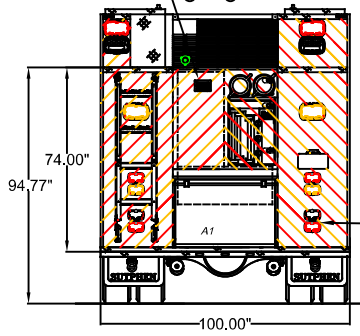

WHELEN M6
TAIL LIGHTS
MOUNTED
INDIVIDUALLY

STAINLESS STEEL
ACCESS LADDER

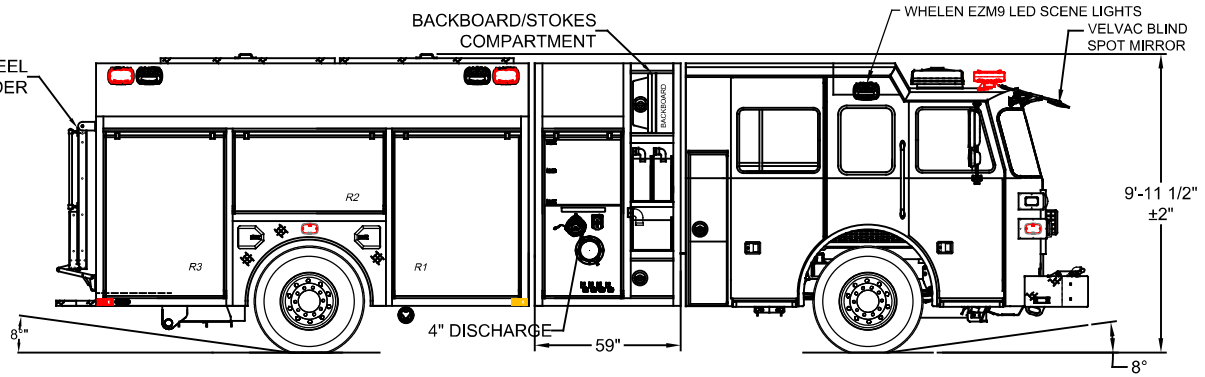

LEFT SIDE COMPARTMENTATION				
COMPT	DOORS	OPENING DIMENSIONS	INSIDE DIMENSIONS	VOLUME
L1	ROLL-UP	50" w X 62 7/8" h	56" w X 72" h X 27 1/4" d	63.6 CU. FT.
L2	ROLL-UP	57" w X 33 5/8" h	64" w X 38" h X 27 1/4" d	38.4 CU. FT.
L3	ROLL-UP	46" w X 62 7/8" h	53" w X 72" h X 27 1/4" d	62.5 CU. FT.
H1	LIFT-UP		150" L X 29" w X 21" h	52.9 CU. FT.

RIGHT SIDE COMPARTMENTATION				
COMPT	DOORS	OPENING DIMENSIONS	INSIDE DIMENSIONS	VOLUME
R1	ROLL-UP	50" w X 56 7/8" h	56" w X 72" h X 27 1/4" d	63.6 CU. FT.
R2	ROLL-UP	57" w X 27 5/8" h	64" w X 38" h X 27 1/4" d	38.4 CU. FT.
R3	ROLL-UP	50" w X 56 7/8" h	53" w X 72" h X 27 1/4" d	62.5 CU. FT.
H2	LIFT-UP		173.5" L X 29" w X 21" h	56.9 CU. FT.

REAR STEP COMPARTMENT				
COMPT	DOORS	OPENING DIMENSIONS	INSIDE DIMENSIONS	VOLUME
A1	ROLL-UP	37 1/2" w X 31" h	40" w X 30" h X 30 1/2" d	21.9 CU. FT.

HALE QMAX-XS 1500 SINGLE STAGE
750 GALLONS OF WATER

TOTAL: 462.7 CU.FT.

FENDER STORAGE
LFF: SINGLE SCBA
LRF: SINGLE SCBA
RFF: SINGLE SCBA
RRF: SINGLE SCBA

LADDER CHUTE
24FT 2-SEC
14FT ROOF
10FT ATTIC
(2) PIKE POLES
(2) 10FT HARD SUCTION

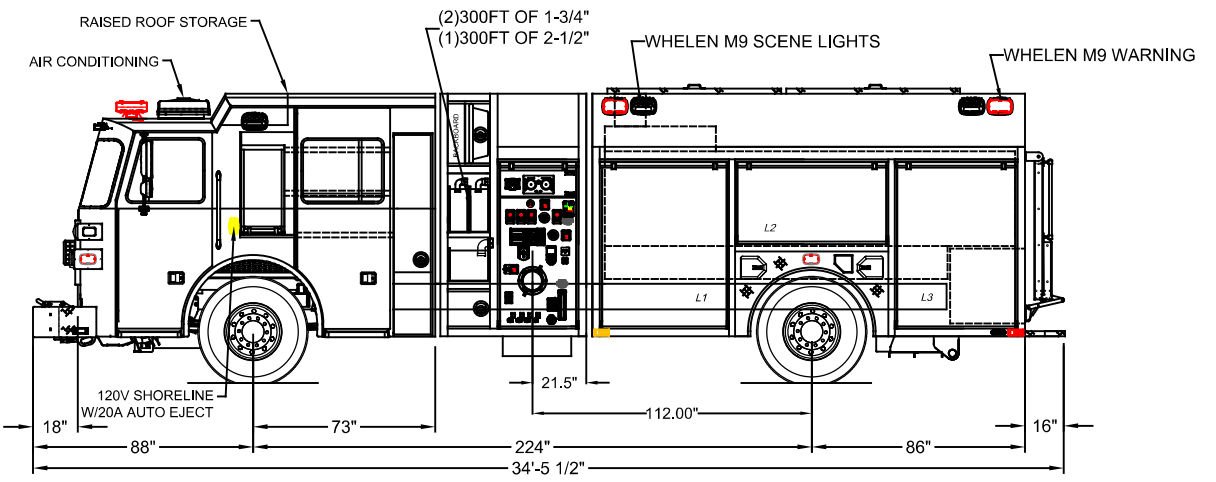
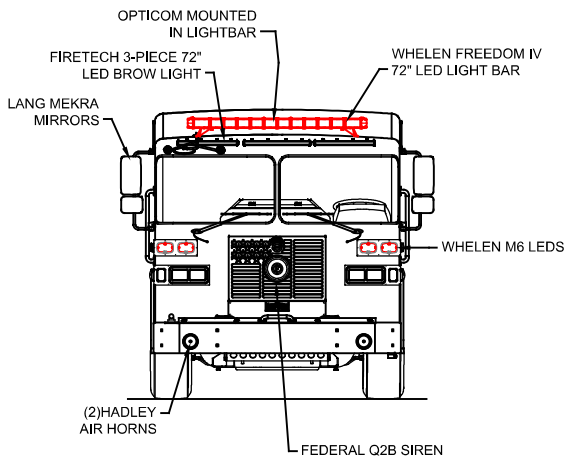
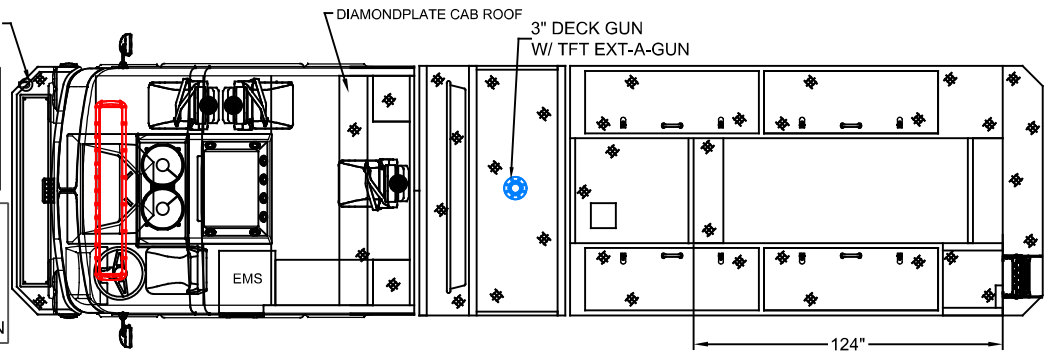

DIMENSIONS SHOWN ON THIS DRAWING ARE APPROXIMATE AND ARE SUBJECT TO MINOR DEVIATIONS DURING CONSTRUCTION.	CUSTOMER APPROVAL				DRAWN BY: S.DORFMAN		
	NAME: _____				DATE: 12/1/22		
IN THE EVENT OF A DISCREPANCY BETWEEN THE SUTPHEN SPECIFICATIONS AND DRAWING, THE SUTPHEN SPECIFICATIONS SHALL PREVAIL.	TITLE: _____		Changes from Pre-Con		SED 4/19/23		WALLINGFORD FIRE DEPARTMENT WALLINGFORD, CT
DRAWING IS FOR REFERENCE ONLY. SOME ITEMS PROPOSED MAY NOT BE SHOWN OR NOTED.	DATE: _____		REV.	DESCRIPTION	BY	DATE	

THIS PRINT IS PROVIDED ON A RESTRICTED BASIS AND IS NOT TO BE USED IN ANY WAY DETRIMENTAL TO THE INTEREST OF SUTPHEN CORPORATION.