

Left Side Compartmentation				
Compt	Doors	Opening Dimensions	Inside Dimensions WxHxD	Volume
L1	Roll Up	23x49	30x59x24.25	24.8 CU FT
L2	Roll Up	53x18	60x28x24.25	32 CU FT
L3	Roll Up	43x49	50x59x24.25	41.4 CU FT
Right Side Compartmentation				
Compt	Doors	Opening Dimensions	Inside Dimensions	Volume
R1	Roll Up	23x35	30x45x24.25	18.9 CU FT
R3	Roll Up	43x35	50x45x24.25	31.6 CU FT
Rear Compartmentation				
Compt	Doors	Opening Dimensions	Inside Dimensions	Volume
A1	Roll Up	41x26	48x36x22.25	22.3 CU FT

LADDER RACK  
 24' 2" SEC  
 14' ROOF  
 10' FOLDING

HALE QMAX-1500 GPM SS  
 750 GAL WATER  
 HALE SMART FOAM 2.1  
 20 GAL FOAM

Total Volume  
 171 CU Ft

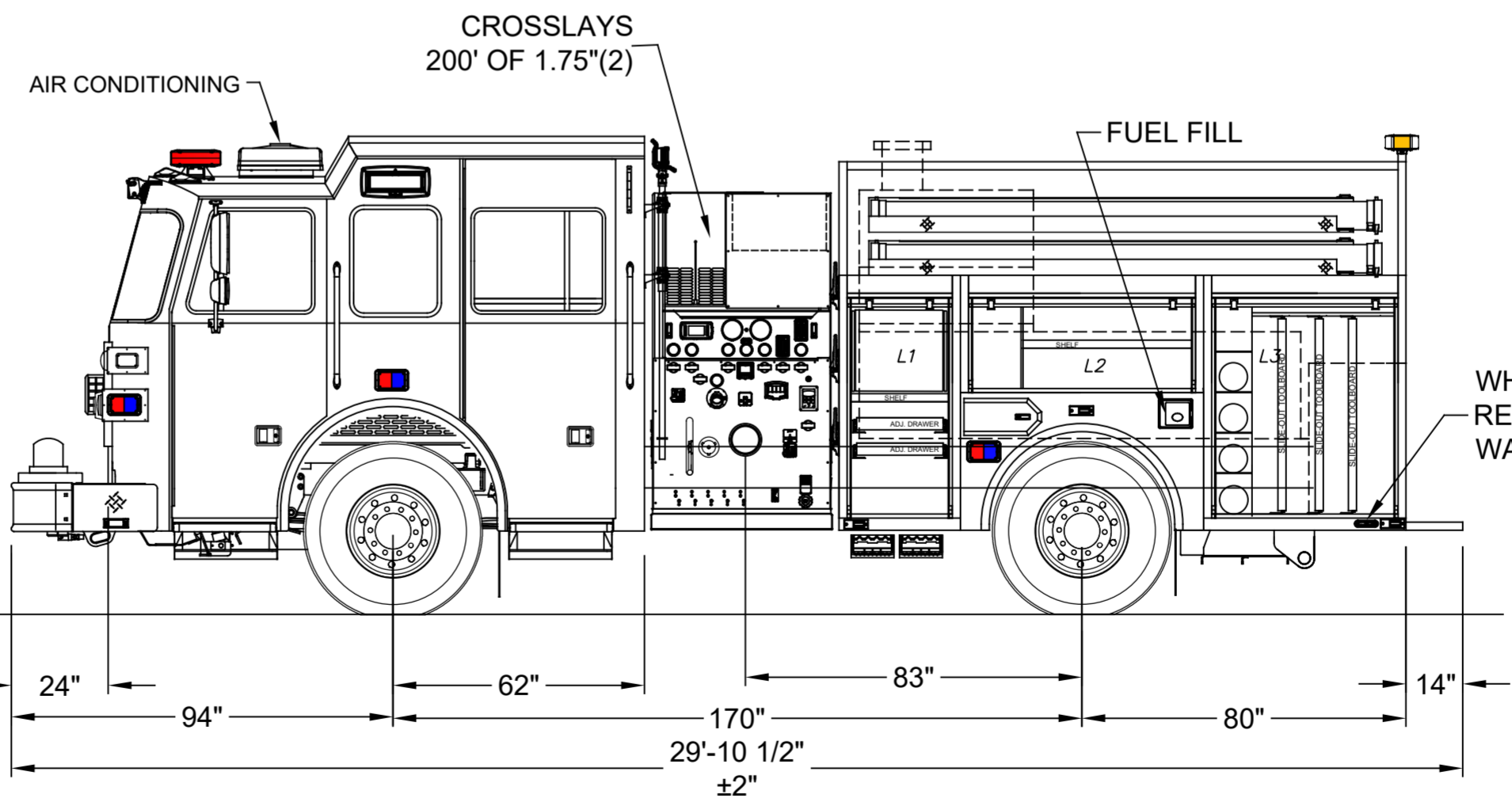
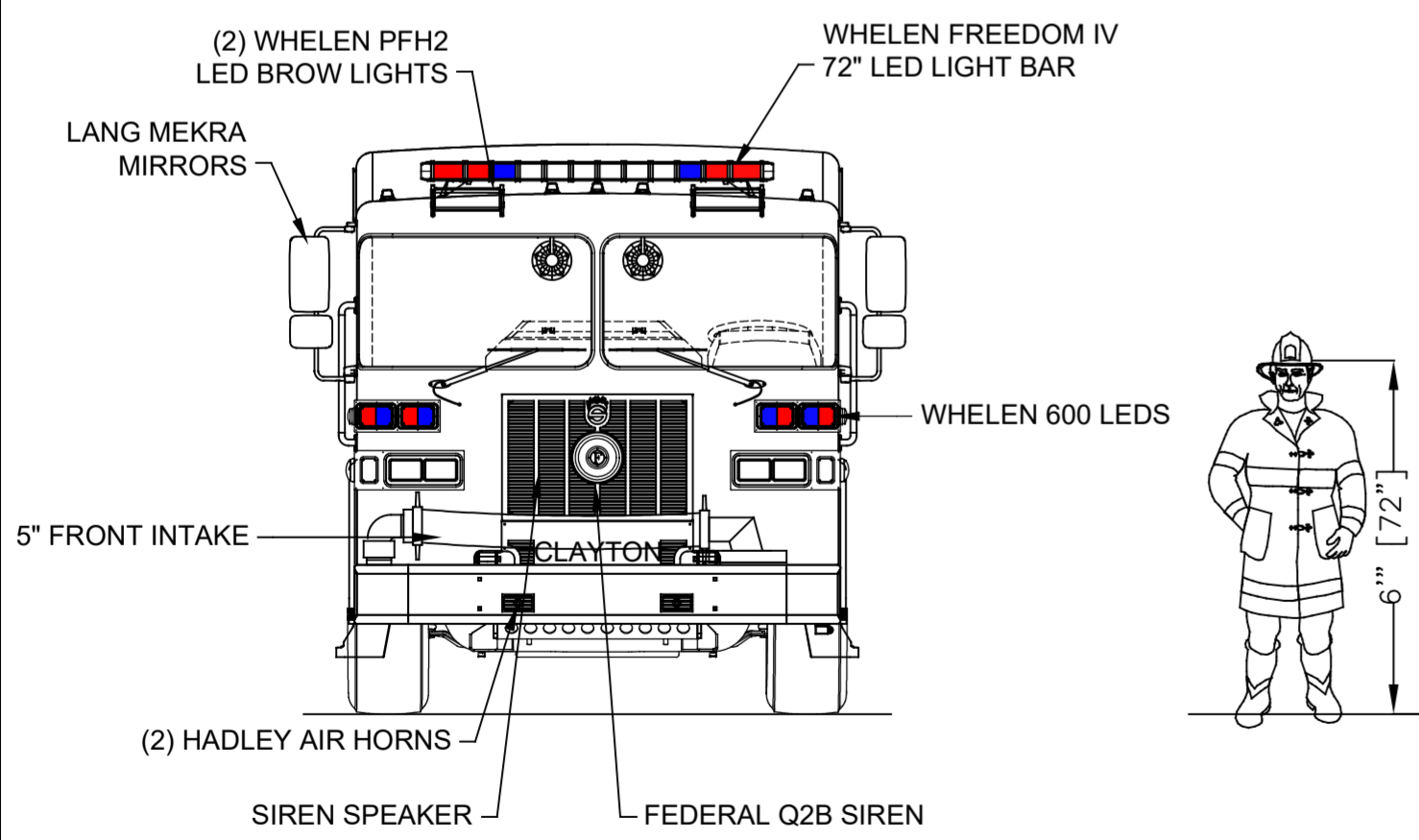
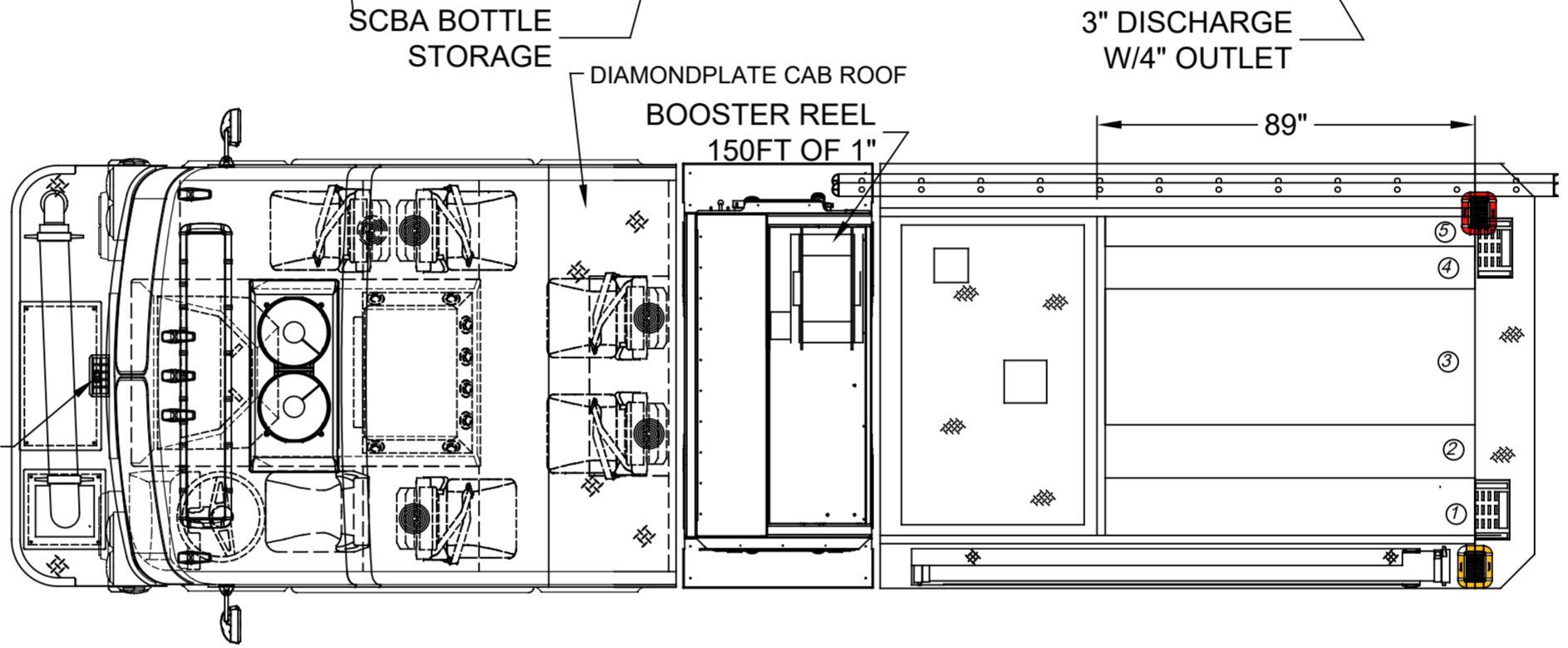

DIMENSIONS SHOWN ON THIS DRAWING ARE APPROXIMATE AND ARE SUBJECT TO MINOR DEVIATIONS DURING CONSTRUCTION.  
 IN THE EVENT OF A DISCREPANCY BETWEEN THE SUTPHEN SPECIFICATIONS AND DRAWING, THE SUTPHEN SPECIFICATIONS SHALL PREVAIL.  
 DRAWING IS FOR REFERENCE ONLY. SOME ITEMS PROPOSED MAY NOT BE SHOWN OR NOTED.

CUSTOMER APPROVAL

NAME: \_\_\_\_\_

TITLE: \_\_\_\_\_

DATE: \_\_\_\_\_

REV.	DESCRIPTION	BY	DATE
B	CHANGE M6 TO 600'S	SED	12/01/22
A	CHANGES FROM PRE-CON	SED	11/28/22

THIS PRINT IS PROVIDED ON A RESTRICTED BASIS AND IS NOT TO BE USED IN ANY WAY DETRIMENTAL TO THE INTEREST OF SUTPHEN CORPORATION.

DRAWN BY:  
 S.DORFMAN  
 DATE:  
 8/31/22  
 MFG. FACILITY:  
 SUTPHEN EAST LAKE ARIEL, PA

TOWN OF CLAYTON FIRE DISTRICT  
 CLAYTON, NY  
 PROGRAM 2 PUMPER - S1-ST5  
 DWG. NO.: HS-7571